

Candidate Name	Centre Number					Candidate Number				
						0				



GCSE

MATHEMATICS  
UNIT 2: CALCULATOR-ALLOWED  
FOUNDATION TIER

SPECIMEN PAPER SUMMER 2017

1 HOUR 30 MINUTES

**ADDITIONAL MATERIALS**

A calculator will be required for this paper.

A ruler, protractor and a pair of compasses may be required.

**INSTRUCTIONS TO CANDIDATES**

Write your name, centre number and candidate number in the spaces at the top of this page.

Answer **all** the questions in the spaces provided in this booklet.

Take  $\pi$  as 3.14 or use the  $\pi$  button on your calculator.

**INFORMATION FOR CANDIDATES**

You should give details of your method of solution when appropriate.

Unless stated, diagrams are not drawn to scale.

Scale drawing solutions will not be acceptable where you are asked to calculate.

The number of marks is given in brackets at the end of each question or part-question.

The assessment will take into account the quality of your linguistic and mathematical organisation, communication and accuracy in writing in question 9.

For Examiner's use only		
Question	Maximum Mark	Mark Awarded
1.	2	
2.	3	
3.	4	
4.	3	
5.	3	
6.	4	
7.	5	
8.	4	
9.	6	
10.	3	
11.	3	
12.	4	
13.	4	
14.	3	
15.	3	
16.	6	
17.	2	
18.	3	
<b>TOTAL</b>	<b>65</b>	

**Formula list**

**Area of a trapezium** =  $\frac{1}{2}(a + b)h$

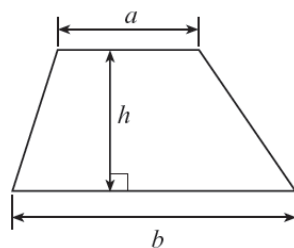

1. The profit made by a charity event is given by the formula

$$\text{profit} = \text{number of tickets sold} \times \text{£5} - \text{cost of expenses.}$$

Calculate the profit made when 84 tickets were sold and the cost of the expenses was £120. [2]

.....

.....

.....

.....

.....

2. (a) What is the special name given to the straight line shown in the diagram below? [1]

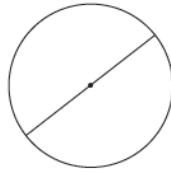

Circle your answer.

Radius          Diameter          Arc          Circumference          Tangent

- (b) What is the special name given to the straight line shown in the diagram below? [1]

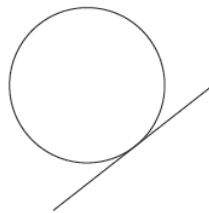

Circle your answer.

Radius          Diameter          Arc          Circumference          Tangent

- (c) What is the special name given to the shape below? [1]

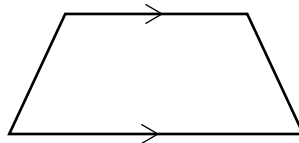

Circle your answer.

Parallelogram          Rectangle          Rhombus          Kite          Trapezium

3.

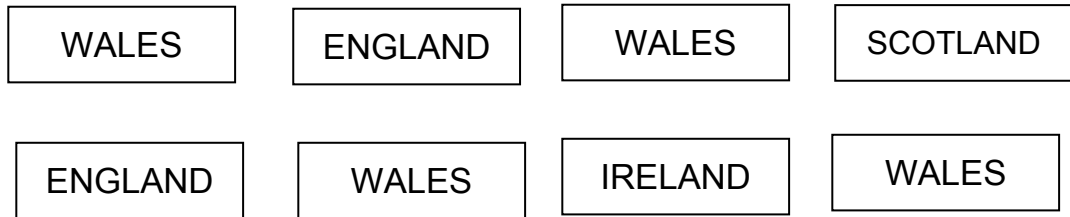

Alun has the eight cards shown above. He chooses one card at random.

(a) On the probability scale below, mark the points A, B and C where:

**A** is the probability of Alun choosing a card with WALES written on it.

**B** is the probability of Alun choosing a card with FRANCE written on it.

**C** is the probability of Alun choosing a card with ENGLAND written on it.

[3]

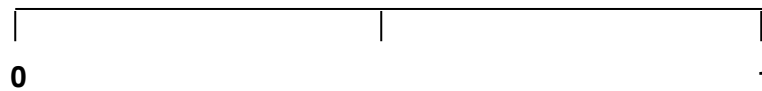

(b) The probability of Alun choosing a card at random with SCOTLAND written on it is  $\frac{1}{8}$ .

What is the probability of Alun choosing a card that does **not** have SCOTLAND written on it?

[1]

.....

4. Using the two instructions given, fill in the blanks in the grid below.

[3]

Each column must add up to 10

1	2	3	
3	4	-5	
	4		
1	0	9	0

Each row must add up to 10

.....

.....

.....

.....

5. (a) In each of the following diagrams, shade **the smallest number** of squares required to answer the question.

(i) Shade the smallest number of squares required to make the line  $AB$  a line of symmetry. [1]

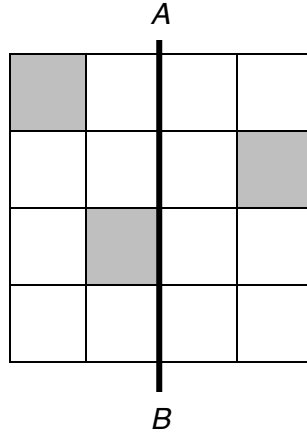

(ii) Shade the smallest number of squares required to make the line  $PQ$  a line of symmetry. [1]

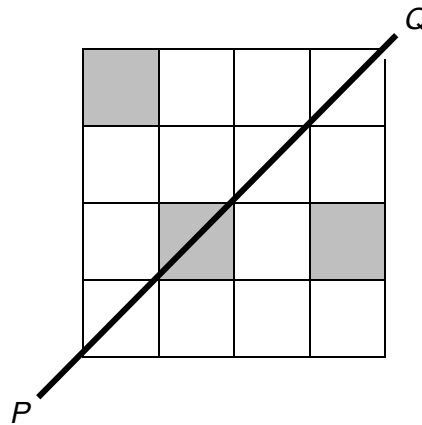

(b) What is the order of rotational symmetry of the shape shown below? [1]

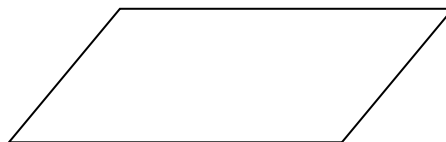

Order of rotational symmetry = .....

6. (a)

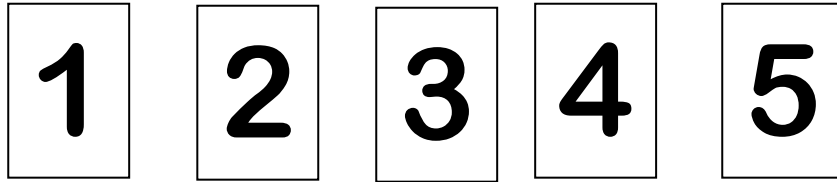

Choose any three cards from those shown above to make a three-digit number that is a multiple of 9.

Give the answer to your calculation.

[2]

--	--	--

 $\div 9 = \dots\dots\dots$

.....

.....

.....

.....

(b) Dylan is 12 years older than Lois.  
Dylan is also three times as old as Lois.  
How old are Dylan and Lois?

[2]

.....

.....

.....

.....

Dylan is .....years old

Lois is .....years old.



7. (a) Solve the following equations.

(i)  $7x = 21$  [1]

.....  
.....

(ii)  $x + 5 = 9$  [1]

.....  
.....

(b) Evaluate  $2a - b + \frac{1}{2}c$ , given that  $a = 3$ ,  $b = 4$  and  $c = 10$ . [2]

.....  
.....  
.....  
.....

(c) Scarves are sold outside a football ground at £8 each.  
Write an expression for the cost, in pounds, of  $n$  of these scarves. [1]

.....  
.....

8. (a) Find the size of angle  $a$ . [2]

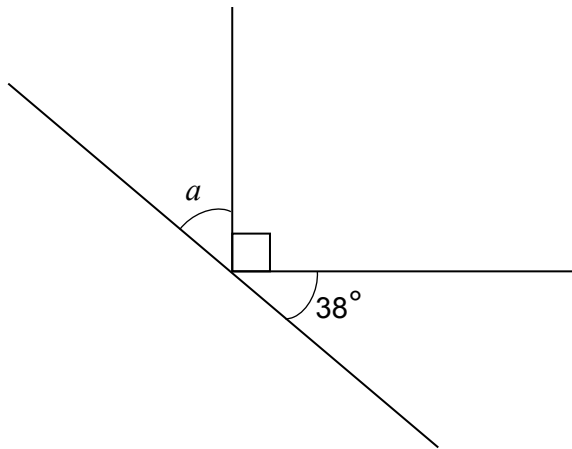

*Diagram not drawn to scale*

.....

.....

.....

.....

- (b) Find the size of angle  $b$ . [2]

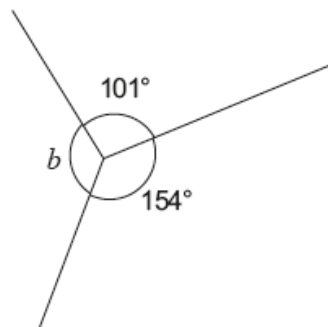

*Diagram not drawn to scale*

.....

.....

.....



10. Find the size of angle  $x$ .

[3]

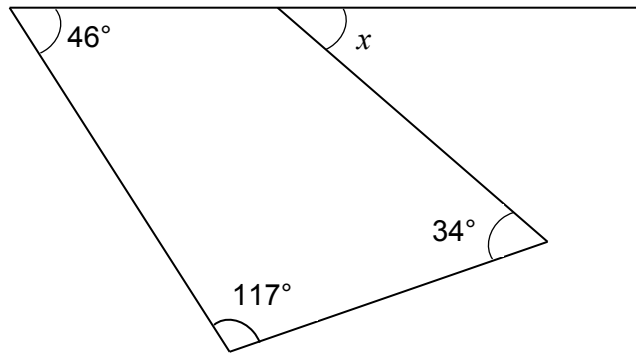

*Diagram not drawn to scale*

.....

.....

.....

.....

$x = \text{.....}^\circ$

11. A number machine is shown below.



Circle your answer in each of the following.

- (a) When the INPUT is 4 the OUTPUT is

33                      -9                      -17                      9                      17

[1]

- (b) When the OUTPUT is 15 the input is

38                      -38                      -12                      12                      -2

[1]

- (c) When the INPUT is  $n$  the OUTPUT is

$3n - 7$                        $n - 21$                        $7(n - 3)$                        $-21n$                        $3(n - 7)$

[1]

12. A fifth number is to be added to the four numbers shown below.

6      10      15      21

The mean of this new larger set of numbers is bigger than the mean of the original set of four numbers by 1.

What is the value of the new number? [4]

.....

.....

.....

.....

.....

.....

.....

.....

New number = .....

13. Shape A is a cube.  
Shape B is a cuboid.  
Both shape A and shape B have the same volume.  
What is the height of shape B?

[4]

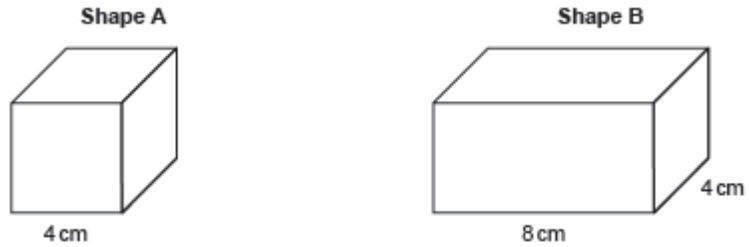

*Diagrams not drawn to scale*

.....

.....

.....

.....

.....

.....

.....

14. The two pie charts below show the ratio between the number of girls and the number of boys in each of two different classes.

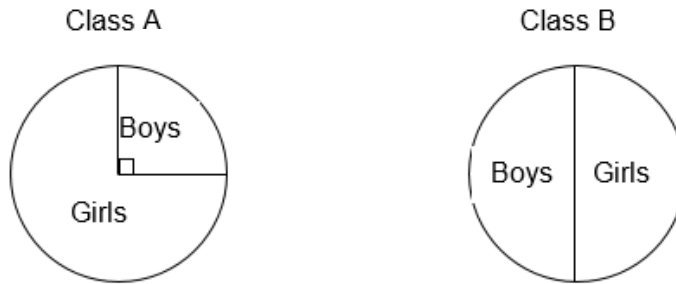

There are **more** girls in class B than in class A.

Complete the table below to show a **possible** set of numbers that will satisfy all of the above information. [3]

	Girls	Boys
Class A		
Class B		

Working space:

.....

.....

.....

.....

.....



- 15.** The angles of a triangle are  $x^\circ$ ,  $2x^\circ$  and  $3x^\circ$ .  
Form an equation in  $x$ , and use your equation to find the sizes of the three angles.

[3]

.....

.....

.....

.....

.....

.....

.....

.....

16. The universal set,  $\mathcal{E} = \{6, 7, 8, 9, 10, 11, 12, 13, 14, 15, 16, 17, 18\}$

Set A is the multiples of 3.

Set B is the multiples of 4.

(a) Complete the Venn diagram.

[4]

.....

.....

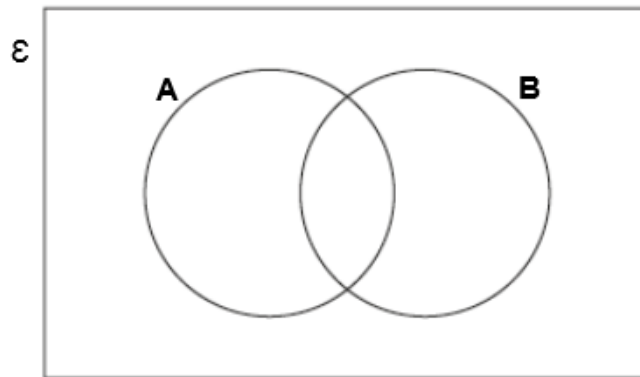

(b) What is the probability that a number selected at random from this universal set is a multiple of 3 but not a multiple of 4? [2]

.....

.....

.....

17. Calculate  $\frac{8.4 \times 3.7}{5.3 + 1.8}$ . Give your answer correct to 2 decimal places. [2]

.....

.....

.....

18. Describe **fully** the transformation that transforms shape A onto shape B. [3]

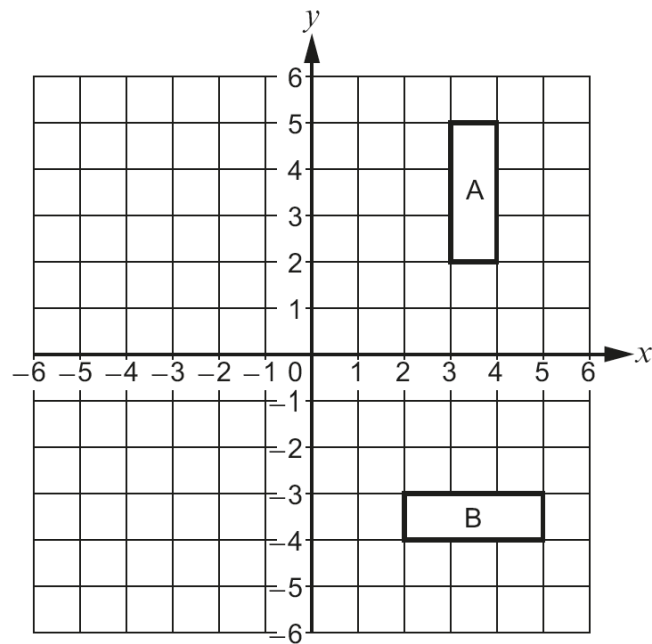

.....

.....

.....

.....