

Candidate Name	Centre Number					Candidate Number				
						0				



GCSE

MATHEMATICS  
UNIT 2: CALCULATOR-ALLOWED  
INTERMEDIATE TIER

SPECIMEN PAPER SUMMER 2017

1 HOUR 45 MINUTES

**ADDITIONAL MATERIALS**

A calculator will be required for this paper.

A ruler, protractor and a pair of compasses may be required.

**INSTRUCTIONS TO CANDIDATES**

Write your name, centre number and candidate number in the spaces at the top of this page.

Answer **all** the questions in the spaces provided in this booklet.

Take  $\pi$  as 3.14 or use the  $\pi$  button on your calculator.

**INFORMATION FOR CANDIDATES**

You should give details of your method of solution when appropriate.

Unless stated, diagrams are not drawn to scale.

Scale drawing solutions will not be acceptable where you are asked to calculate.

The number of marks is given in brackets at the end of each question or part-question.

The assessment will take into account the quality of your linguistic and mathematical organisation, communication and accuracy in writing in question 15.

For Examiner's use only		
Question	Maximum Mark	Mark Awarded
1.	3	
2.	3	
3.	4	
4.	4	
5.	7	
6.	3	
7.	6	
8.	4	
9.	5	
10.	5	
11.	5	
12.	3	
13.	4	
14.	4	
15.	8	
16.	3	
17.	3	
18.	6	
<b>TOTAL</b>	<b>80</b>	

**Formula list**

**Area of a trapezium** =  $\frac{1}{2}(a+b)h$

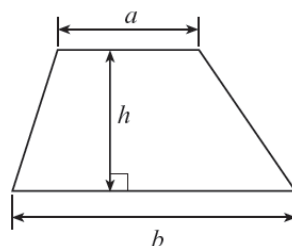

**Volume of a prism** = area of cross section  $\times$  length

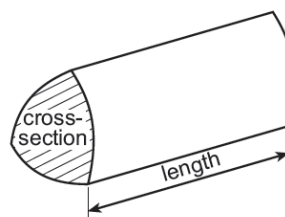

1. Find the size of angle  $x$ .

[3]

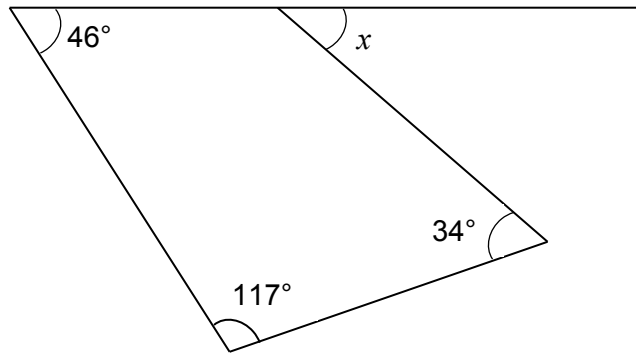

*Diagram not drawn to scale*

.....

.....

.....

.....

$x = \text{.....}^\circ$

2. A number machine is shown below.



Circle your answer in each of the following.

- (a) When the INPUT is 4 the OUTPUT is

33                       $-9$                        $-17$                       9                      17

[1]

- (b) When the OUTPUT is 15 the input is

38                       $-38$                        $-12$                       12                       $-2$

[1]

- (c) When the INPUT is  $n$  the OUTPUT is

$3n - 7$                        $n - 21$                        $7(n - 3)$                        $-21n$                        $3(n - 7)$

[1]

3. A fifth number is to be added to the four numbers shown below.

6      10      15      21

The mean of this new larger set of numbers is bigger than the mean of the original set of four numbers by 1.

What is the value of the new number? [4]

.....

.....

.....

.....

.....

.....

.....

.....

New number = .....

4. Shape A is a cube.  
Shape B is a cuboid.  
Both shape A and shape B have the same volume.  
What is the height of shape B?

[4]

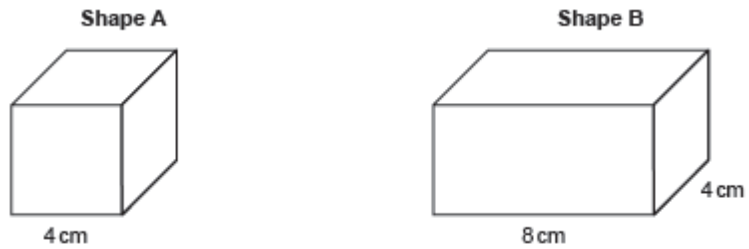

*Diagrams not drawn to scale*

.....

.....

.....

.....

.....

.....

.....

.....

.....

5. (a) A hospital collected data on the age group of each of 120 people that were treated as outpatients on a particular day.

The results are summarised below.

Age Group	Number of people
Pre-school	18
School	24
60 and over	35
Others	43

Draw a pie chart to illustrate these results.  
 You should show how you calculated the angles of your pie chart.

[4]

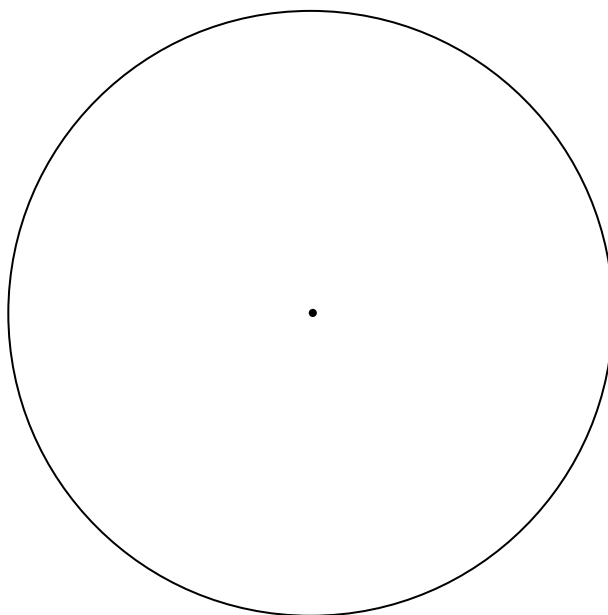

.....

.....

.....

.....

- (b) The two pie charts below show the ratio between the number of girls and the number of boys in each of two different classes.

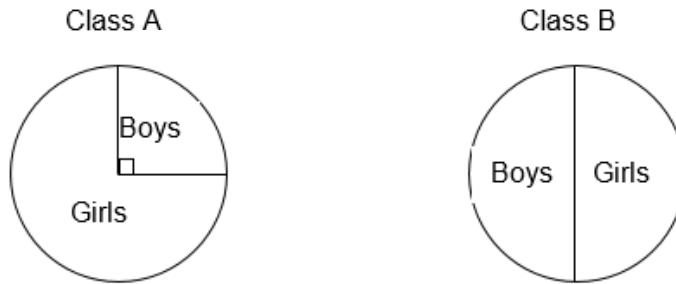

There are **more** girls in class B than in class A.

Complete the table below to show a **possible** set of numbers that will satisfy all of the above information. [3]

	Girls	Boys
Class A		
Class B		

Working space:

.....

.....

.....

.....

.....





7. The universal set,  $\mathcal{E} = \{6, 7, 8, 9, 10, 11, 12, 13, 14, 15, 16, 17, 18\}$

Set A is the multiples of 3.

Set B is the multiples of 4.

- (a) Complete the Venn diagram.

[4]

.....

.....

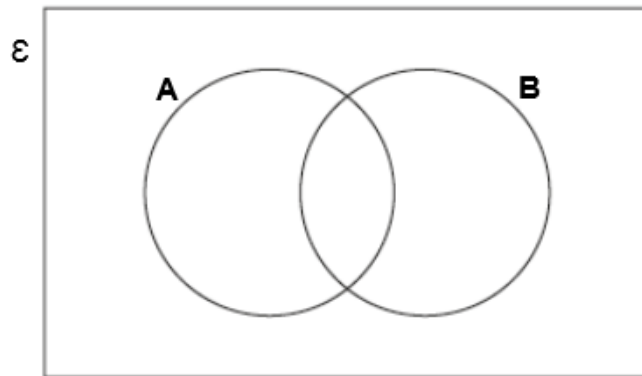

- (b) What is the probability that a number selected at random from this universal set is a multiple of 3 but not a multiple of 4? [2]

.....

.....

.....

8. (a) Calculate  $\frac{8.4 \times 3.7}{5.3 + 1.8}$ . Give your answer correct to 2 decimal places. [2]

.....

.....

.....

- (b) What is the number 80 953 written correct to 3 significant figures?  
Circle your answer. [1]

810                      80 900                      80 000                      81 000                      953

- (c) What is the number 0.07415 written correct to 2 significant figures?  
Circle your answer. [1]

0.07                      0.1                      0.08                      0.0                      0.074

9. (a) Reflect the shape A in the line  $x = 1$ . [2]

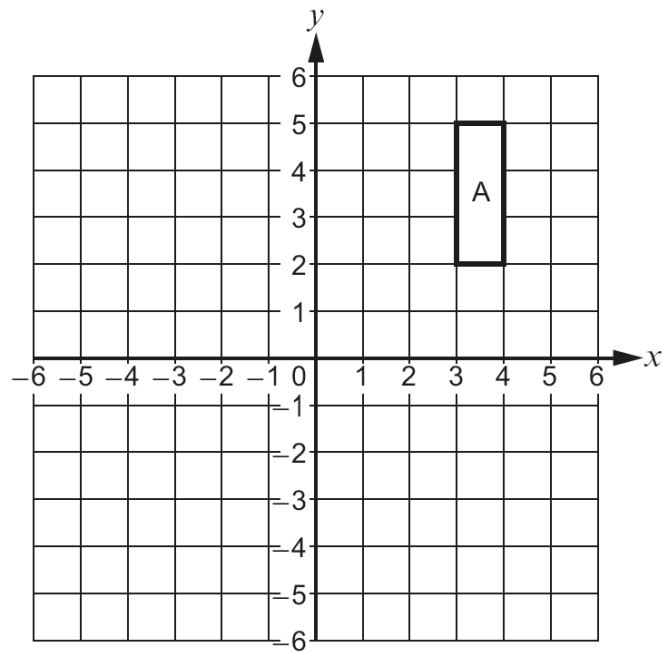

- (b) Describe **fully** the transformation that transforms shape A onto shape B. [3]

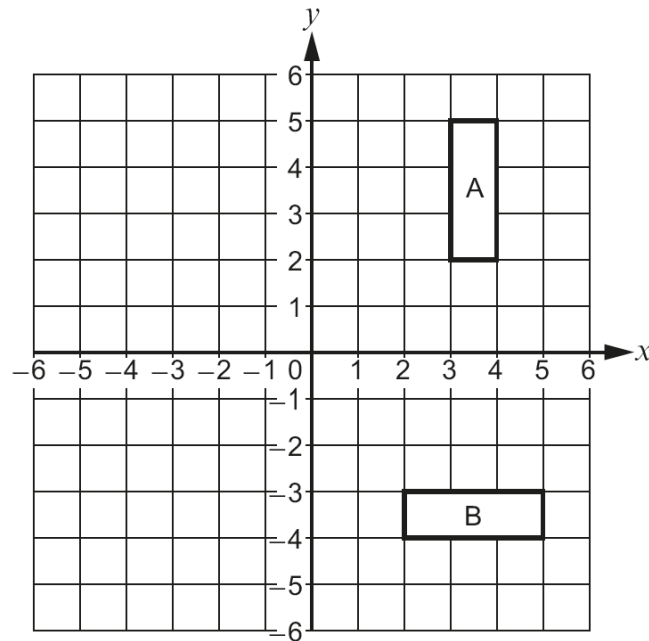

.....

.....

.....

.....

- 10.** Four of the interior angles of a seven-sided polygon are  $114^\circ$ ,  $150^\circ$ ,  $160^\circ$  and  $170^\circ$ .  
The other three interior angles of this polygon are equal.  
Calculate the size of each of the other three interior angles. [5]

.....

.....

.....

.....

.....

.....

**11.** (a) Express 144 as the product of its prime factors in index form. [3]

.....  
.....  
.....  
.....  
.....  
.....  
.....

(b) Given that  $60 = 2^2 \times 3 \times 5$ , find

(i) the highest common factor (HCF) of 144 and 60, [1]

.....  
.....  
.....

(ii) the lowest common multiple (LCM) of 144 and 60. [1]

.....  
.....  
.....

12. (a) Solve the inequality given below. [2]

$$7n < 5n + 11$$

.....

.....

.....

.....

- (b) Give the largest integer value for  $n$  that satisfies this inequality. [1]

$$n = \dots\dots\dots$$





14. Carys has a Monday to Friday job and a weekend job.  
 Working Monday to Friday and working weekends are independent events.  
 In any given week, the probability that Carys works every day from Monday to Friday is 0.65.  
 The probability that she works both days during a weekend is 0.2.

(a) Complete the following tree diagram. [2]

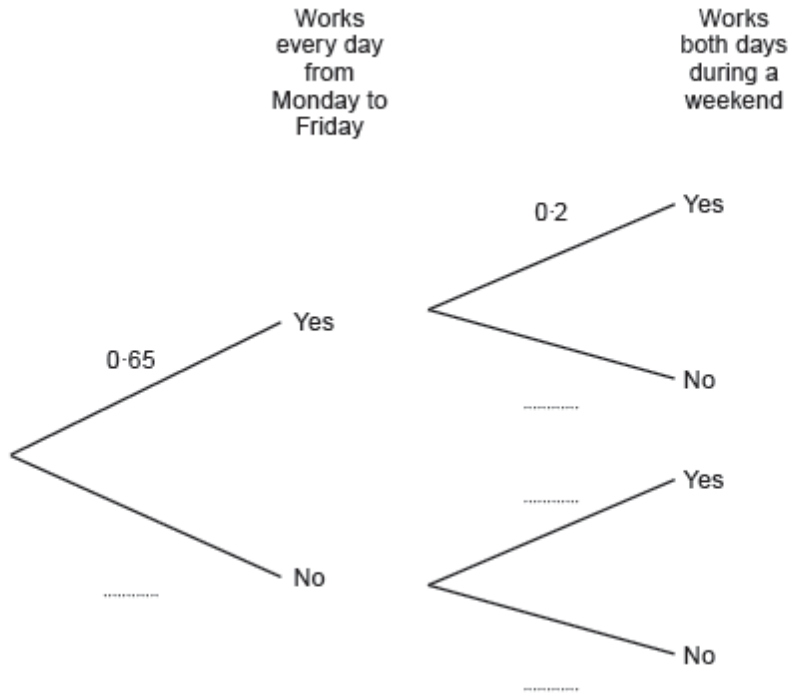

(b) Calculate the probability that next week Carys will work every day from **Monday to Sunday**. [2]

.....

.....

.....



16. Factorise  $x^2 - x - 20$ , and hence solve  $x^2 - x - 20 = 0$ . [3]

.....

.....

.....

.....

.....

17. A sketch of the graph of the straight line  $y = 7x + 2$  is shown below.

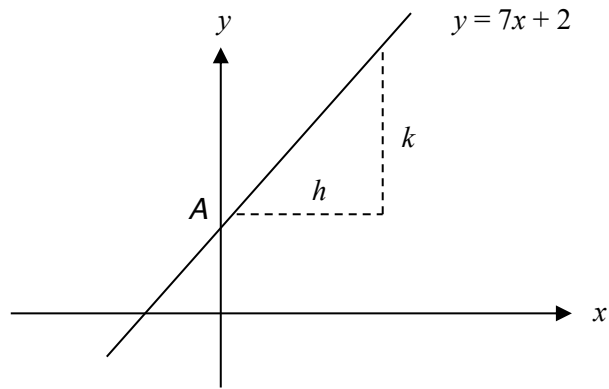

Diagram not drawn to scale

- (a) What are the coordinates of the point A, where the line cuts the  $y$ -axis?  
Circle your answer. [1]

(2, 0)                  (7, 0)                  (0, 2)                  (0, 7)                  (7, 2)

- (b) When  $h$  is equal to 1 unit, what is the value of  $k$ ?  
Circle your answer. [1]

2 units                  7 units                  1 unit                  3.5 units                  14 units

- (c) Which of the following equations is an equation of a straight line that is perpendicular to  $y = 7x + 2$ ?  
Circle your answer. [1]

$y = 7x + 3$                    $y = \frac{x}{7} + 3$                    $y = 7x + 3$                    $y = -\frac{x}{7} + 3$                    $y = 2x + 7$

18.

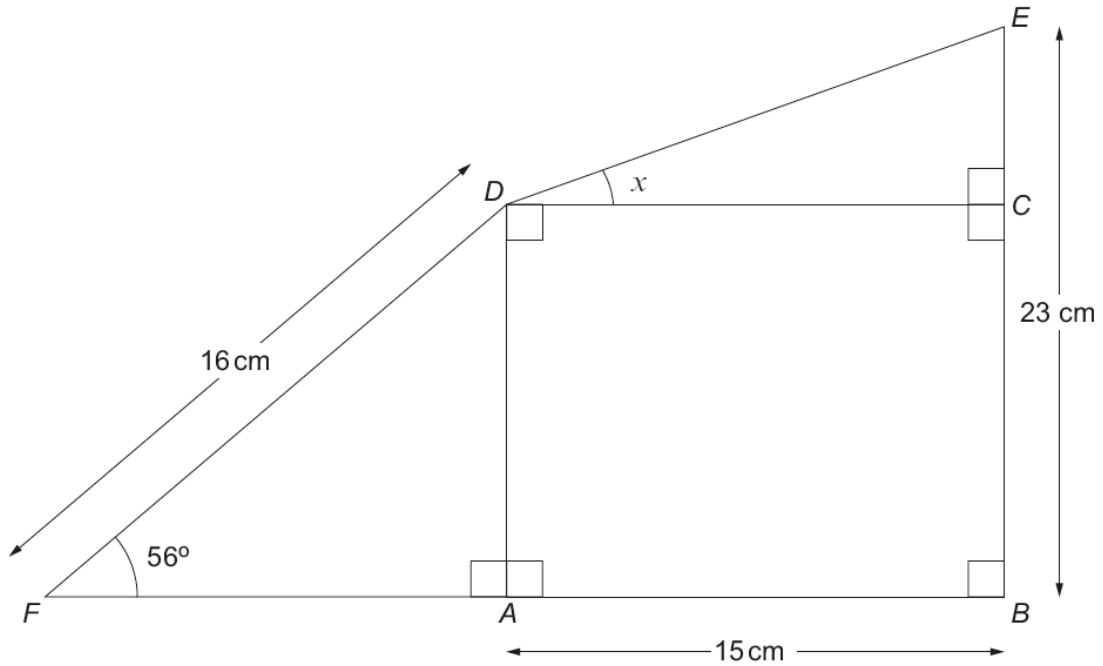

Diagram not drawn to scale

- (a) Calculate the length  $AD$ . [3]

.....

.....

.....

.....

- (b) Find the size of the angle  $x$ . [3]

.....

.....

.....

.....

.....

.....

.....

.....