

Candidate Name	Centre Number					Candidate Number				
						0				



GCSE

MATHEMATICS - NUMERACY

UNIT 2: CALCULATOR-ALLOWED
INTERMEDIATE TIER

SPECIMEN PAPER SUMMER 2017

1 HOUR 45 MINUTES

ADDITIONAL MATERIALS

A calculator will be required for this paper.

A ruler, protractor and a pair of compasses may be required.

INSTRUCTIONS TO CANDIDATES

Write your name, centre number and candidate number in the spaces at the top of this page.

Answer **all** the questions in the spaces provided in this booklet.Take π as 3.14 or use the π button on your calculator.**INFORMATION FOR CANDIDATES**

You should give details of your method of solution when appropriate.

Unless stated, diagrams are not drawn to scale.

Scale drawing solutions will not be acceptable where you are asked to calculate.

The number of marks is given in brackets at the end of each question or part-question.

The assessment will take into account the quality of your linguistic and mathematical organisation, communication and accuracy in writing in question 5(a).

For Examiner's use only		
Question	Maximum Mark	Mark Awarded
1.	7	
2.	2	
3.	4	
4.	3	
5.	9	
6.	4	
7.	6	
8.	6	
9.	4	
10.	7	
11.	7	
12.	7	
13.	5	
14.	5	
15.	4	
TOTAL	80	

Formula list

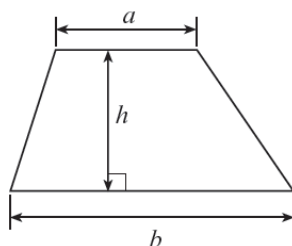

Area of a trapezium = $\frac{1}{2}(a+b)h$

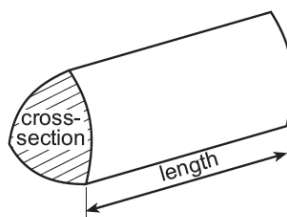

Volume of a prism = area of cross section \times length



1.

	Grapes £3.40 per kg
	Bananas £2.70 per kg
	Apples £1.80 per kg

(a) The price of 1kg of bananas is due to be increased by either $\frac{1}{3}$ or 30%.

(i) How much would 1kg of bananas cost if the price was increased by $\frac{1}{3}$?

Circle your answer [1]

- £4.05 £3.06 £3.60 £3.51 £2.97

(ii) How much would 1kg of bananas cost if the price was increased by 30%?

Circle your answer. [1]

- £3.15 £10.80 £3.60 £3.51 £2.97

(b) The price of 1 kg of apples is to be reduced by $\frac{2}{5}$.

Calculate the new price of 1kg of apples. [2]

.....

.....

.....

(c) The price of peaches is not given in the table.
Rowena buys 0.4kg of grapes and 0.5kg of peaches.
It costs her £3.46 altogether.

What is the price of 1kg of peaches? [3]

.....

.....

.....

.....

2. There were 32 rugby players in the 2013 – 2014 Wales rugby squad.
The mean height of these rugby players was 189 cm.

Circle either TRUE or FALSE for each of the following statements.

[2]

All the rugby players in the squad must have been taller than 189 cm.	TRUE	FALSE
If there was a rugby player of height 191 cm in the squad, there must have been a rugby player of height 187 cm.	TRUE	FALSE
The majority of the rugby players in the squad must have been of height 189 cm.	TRUE	FALSE
If some of the rugby players in the squad were taller than 189 cm, then some must have been shorter than 189 cm.	TRUE	FALSE
Half the rugby players in the squad must have been shorter than 189 cm, and half of the rugby players in the squad must have been taller than 189 cm.	TRUE	FALSE

3. Siôn has gone to a travel agent to book a 7-day holiday at a Spanish resort for July 2016.

He has the following two **definite** requirements:

- He can only be away on holiday between 2 July 2016 and 23 July 2016.
- His flight must land in Malaga.

He would like to have as many as possible of the following four **preferred** conditions met:

- To fly from Cardiff Wales Airport.
- Depart on a Monday.
- Departure time to be before 10:00 a.m.
- The hotel to have a 3-star (***) rating.

Using the following information, choose the best two options from the eight holiday packages listed (Package A to Package H).

His definite requirements **must** be met and **as many as possible** of his preferred conditions should also be met. [4]

July 2016						
Monday	Tuesday	Wednesday	Thursday	Friday	Saturday	Sunday
				1	2	3
4	5	6	7	8	9	10
11	12	13	14	15	16	17
18	19	20	21	22	23	24
25	26	27	28	29	30	31

Hotel	Star Rating
<i>Castilla</i>	* * *
<i>Nou Sol</i>	* * *
<i>Costa Park</i>	* *
<i>Fiesta</i>	* *

Package	Flights		Depart		Return		Hotel
	From	To	Date	Time	Date	Time	
A	Manchester	Malaga	11/7/16	14:00	18/7/16	23:00	<i>Castilla</i>
B	Manchester	Malaga	4/7/16	09:30	11/7/16	15:00	<i>Nou Sol</i>
C	Manchester	Malaga	5/7/16	06:30	12/7/16	15:00	<i>Costa Park</i>
D	Manchester	Seville	4/7/16	08:00	11/7/16	12:30	<i>Nou Sol</i>
E	Cardiff	Malaga	18/7/16	07:30	25/7/16	14:00	<i>Castilla</i>
F	Cardiff	Malaga	6/7/16	10:05	13/7/16	14:00	<i>Fiesta</i>
G	Cardiff	Malaga	11/7/16	17:00	18/7/16	22:00	<i>Castilla</i>
H	Cardiff	Malaga	9/7/16	09:45	16/7/13	05:30	<i>Costa Park</i>

.....

.....

.....

.....

.....

.....

.....

.....

.....

.....

.....

.....

.....

.....

.....

.....

.....

.....

.....

.....

Allowing for as many of his preferred conditions as possible, the two best options for Siôn are:

Package and Package

4. Look at the four graphs labelled **A**, **B**, **C** and **D**, shown below.

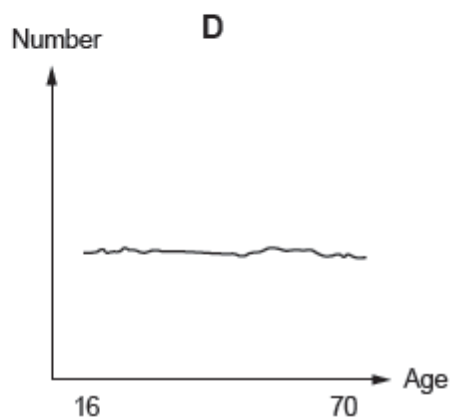
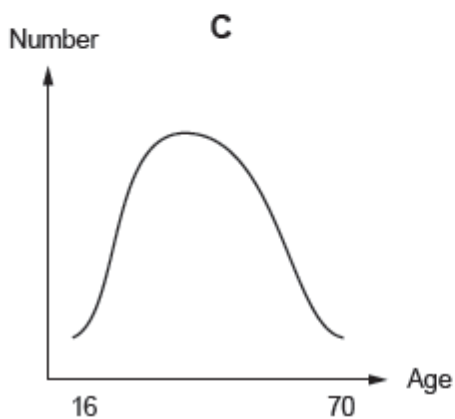
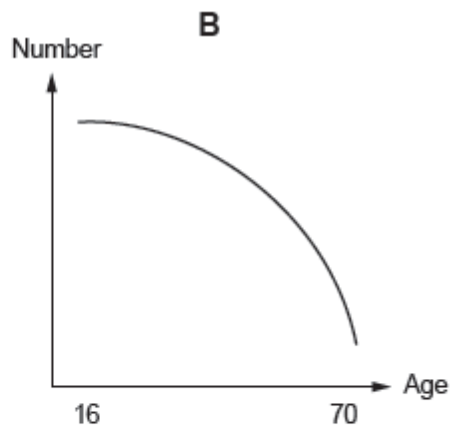
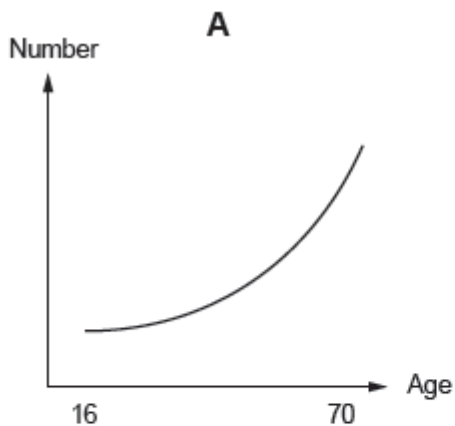

Write down which graph **A**, **B**, **C** or **D**, in each case, is most likely to have the following titles.

[3]

- | | |
|--|-------------|
| 'The number of people in full-time employment.' | Graph |
| 'The number of people who play for a football team.' | Graph |
| 'The number of people who wear glasses.' | Graph |
| 'The number of people who are left-handed.' | Graph |

(b) Gemma's old tablet had a memory capacity of 16 GB.
 Gemma stored music and videos, photos and applications on her tablet.
 The table and pie chart below show the memory status of her 16 GB tablet.

Music and videos	4 GB
Photos	1.3 GB
Applications	4.5 GB
Free space	6.2 GB

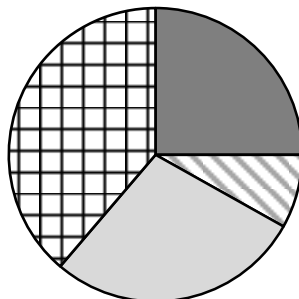

- Music and video
- ▣ Photos
- ▤ Applications
- ▥ Free space

Gemma's new tablet has a memory capacity of 32 GB.
 Gemma transfers the content of her old tablet to the new one.

Which one of the following graphs represents her new tablet's memory status?
 Circle **A**, **B**, **C** or **D**. [1]

<p>A</p> <ul style="list-style-type: none"> ■ Music and video ▣ Photos ▤ Applications ▥ Free space 	<p>B</p> <ul style="list-style-type: none"> ■ Music and video ▣ Photos ▤ Applications ▥ Free space
<p>C</p> <ul style="list-style-type: none"> ■ Music and video ▣ Photos ▤ Applications ▥ Free space 	<p>D</p> <ul style="list-style-type: none"> ■ Music and video ▣ Photos ▤ Applications ▥ Free space

7. The following two pieces of information, given in both kilograms (kg) and pounds (lb), were seen in a cookery magazine.

Use 5 kg (11 lb) of apples. Wash and peel them.

Use 2 lb (0.9 kg) of sugar. Warm the sugar before use.

- (a) Use the information to draw a conversion graph between kilograms and pounds. [3]

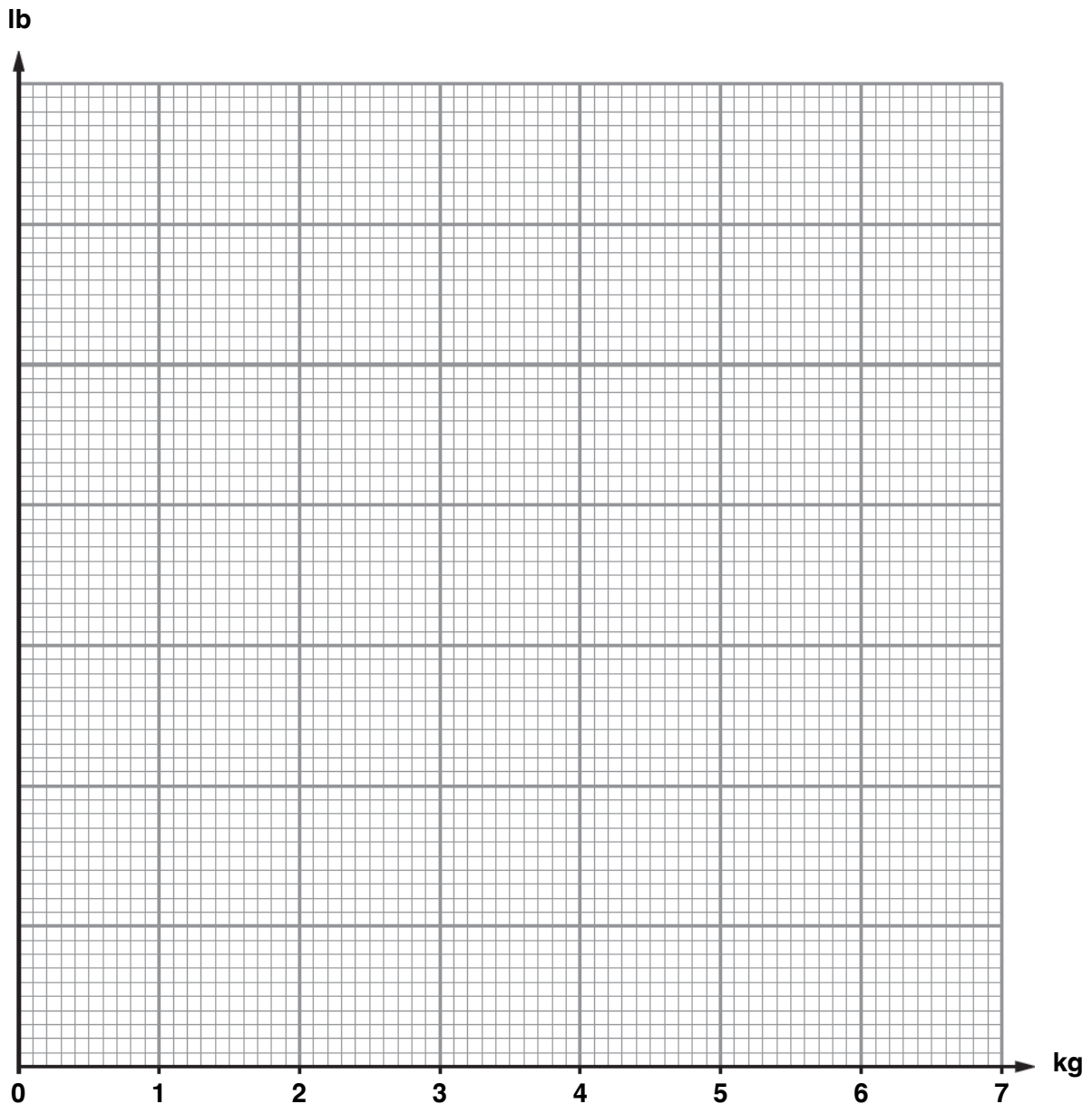

- (b) A person weighs 10 stone. (1 stone = 14 lbs)
Use your graph to estimate the weight of this person in kilograms.
Remember to show the method you have used.

[3]

.....

.....

.....

.....

.....

10. Pack4 is a company that makes cardboard boxes.
 (a) One of their boxes, in the shape of a triangular prism, is shown below.

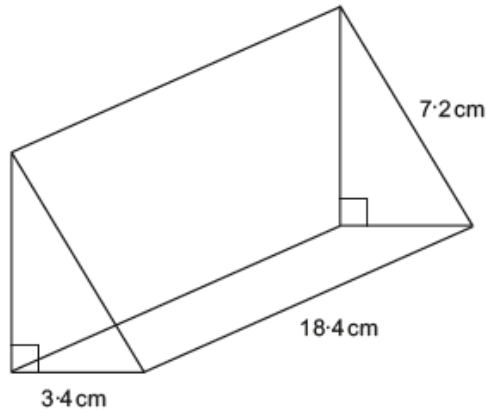

Diagram not drawn to scale

A customer wants a box with a volume of 0.2 litres.

State by how much the volume is greater or less than 0.2 litres, giving your answer in cm^3 correct to 2 significant figures. [6]

.....

.....

.....

.....

.....

.....

.....

.....

.....

.....

- (b) Explain why this may not be a suitable box for the customer. [1]

.....

.....

.....

.....

11. Layla is investigating how much people would be prepared to pay for a bottle of water at an Eisteddfod.



Amount of money (£x)	Number of people
$0 \leq x < 1$	12
$1 \leq x < 2$	44
$2 \leq x < 3$	20
$3 \leq x < 4$	4

She asked a number of people at a concert on Monday how much they would be prepared to pay.

Monday's results are summarised in the table.

- (a) Calculate an estimate for the mean amount of money that a person would be prepared to pay for a bottle of water. [4]

.....

.....

.....

.....

.....

.....

- (b) Monday was a cool day.
 On Tuesday, it was much warmer.
 Layla asked a further 60 people the same question as she did on Monday.
 On Tuesday the mean was £2.30.

Use the data collected over the two days to calculate an estimate for the mean amount of money that a person would be prepared to pay for a bottle of water.

Give your answer correct to the nearest penny. [3]

.....

.....

.....

.....

.....

12. Jane and Tomos own a sandwich business.

- (a) They decide to price sandwiches individually each morning.
 At 3 p.m. any unsold sandwiches are reduced by 45%.
 Any sandwiches still unsold by 4:30p.m. are reduced by a further 20%.

Jane says

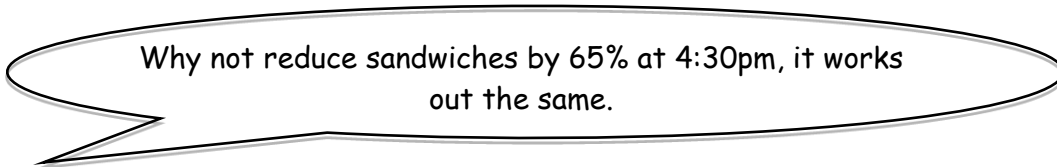

Tomos disagrees with Jane.

Using multipliers, show that Jane is incorrect. [4]

.....

.....

.....

.....

.....

.....

.....

.....

- (b) Write down and simplify two formulae, in terms of P , to calculate the reduced prices of sandwiches at 3 p.m. and at 4:30 p.m.

Let

- P be the full price of the sandwich.
- T be the price of a sandwich at 3p.m.
- R be the price of a sandwich after 4:30p.m. [3]

.....

.....

.....

.....

.....

.....

13.

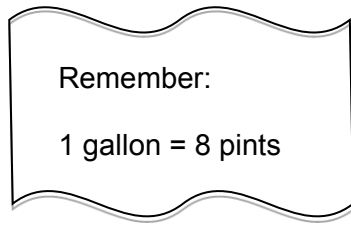

Lowri owns an old van.

It has an average fuel consumption of 7 km per litre.

Calculate an estimate for this fuel consumption in miles per gallon.

[5]

.....

.....

.....

.....

.....

.....

.....

14. The diagram shows the route a dolphin swam from Port Quay to Rig Bay and then to Jay Cliff.

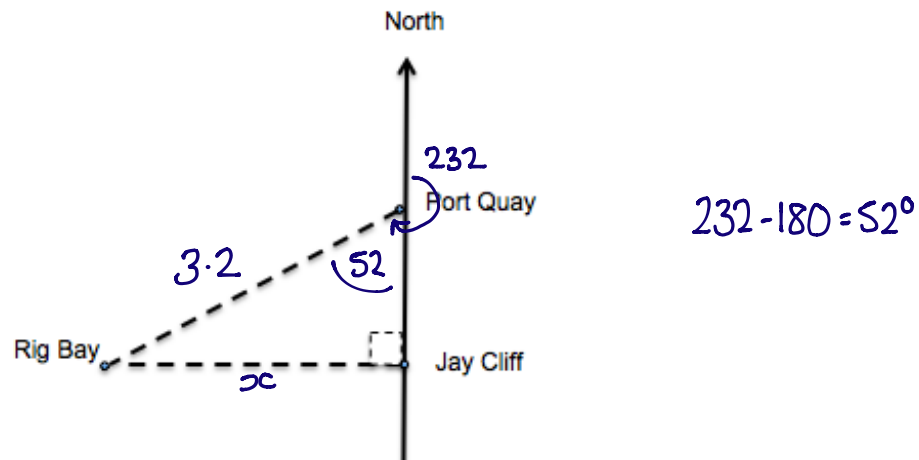

Diagram not drawn to scale

Rig Bay is on a bearing of 232° from Port Quay.
The distance from Port Quay to Rig Bay is 3.2 km.
Calculate how far the dolphin swam altogether

[5]

$$\sin 52 = \frac{x}{3.2}$$

$$x = \sin 52 \times 3.2 = 2.52163$$

$$\text{Total distance} = 3.2 + 2.52 = 5.7216344$$

$$= \underline{\underline{5.7 \text{ km}}}$$

15. *NwyCymru* gas company uses the following formula to calculate how much to charge its customers:

$$\text{charge (in pence)} = (\mathbf{U} \times 11.546 + \mathbf{D} \times 31.48) \times 1.05$$

The number of units of gas used by a customer is **U** and the number of days in the billing period is **D**.

A customer was charged £165.53 over a billing period of 90 days.
Calculate the number of gas units this customer used during this period. [4]

.....

.....

.....

.....

.....

.....

.....