

Trigonometry (H)

A collection of 9-1 Maths GCSE Sample and Specimen questions from AQA, OCR, Pearson-Edexcel and WJEC Eduqas.

Name:	
Total Marks:	

1. A man is working out the height of a vertical tree.

The man is able to measure the angle of elevation of the top of the tree from his measuring instrument.

The measuring instrument is 1.8m above ground level.

When the man is standing 19m from the base of the tree, the angle he measures is 56° .

A sketch of this situation is shown below.

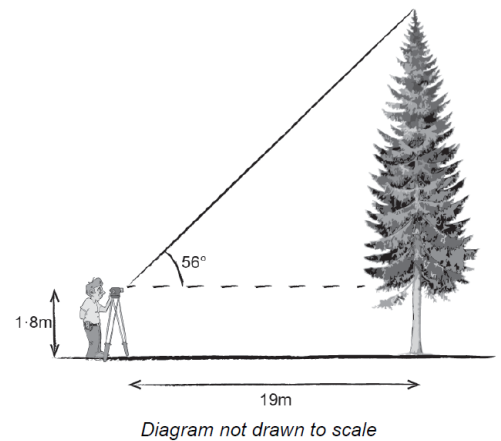

Calculate the full height of the tree.

[4]

2. Here are sketches of four triangles.

In each triangle

the longest side is exactly 1 cm

the other length is given to 2 decimal places.

(a) Circle the value of $\cos 50^\circ$ to 2 decimal places.

- 0.77
- 0.53
- 0.64
- 0.86

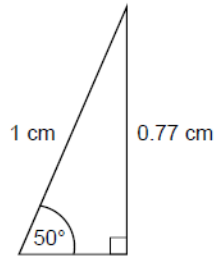

Not drawn accurately

[1]

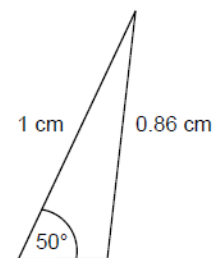

(b) Work out the value of x .

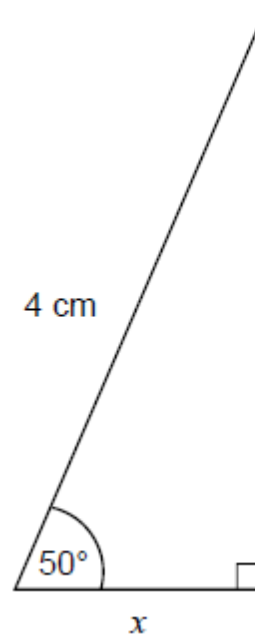

Not drawn accurately

Give your answer to 1 decimal place.

[2]

3. PQR is a right-angled triangle.

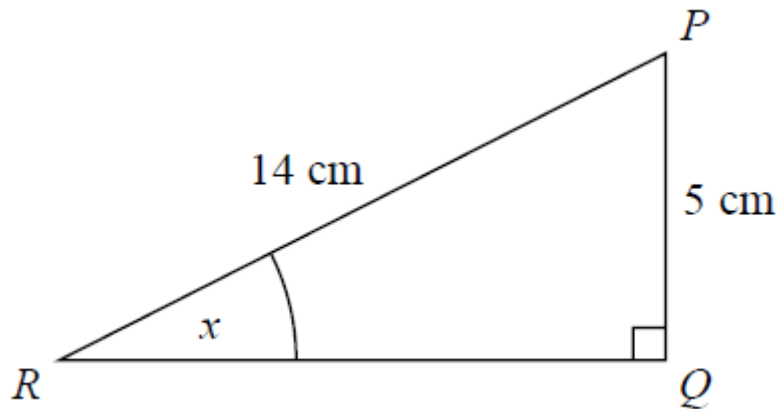

Work out the size of the angle marked x .

Give your answer correct to 1 decimal place.

.....° [2]

4. A pattern is made from two similar trapeziums. The pattern has one line of symmetry.

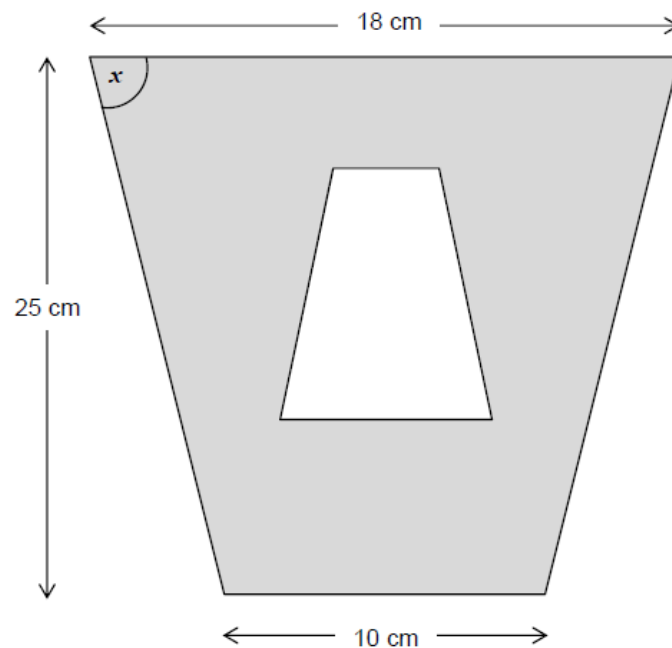

Work out the size of angle x .

[3]

5. The diagram shows a design for a zipwire.

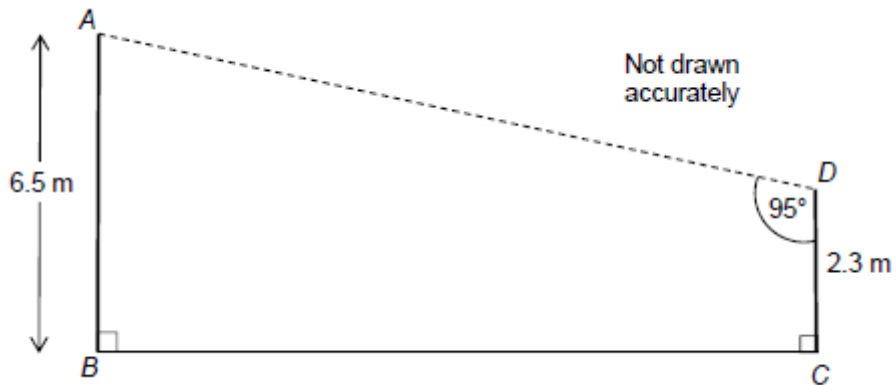

The zipwire will run between the top of two vertical posts, AB and CD.
Work out the distance AD.

[4]

6. In the diagram, ABC is a triangle and line BD is perpendicular to AC.
Angle BAC = 43° , BD = 8 cm and AC = 12 cm.

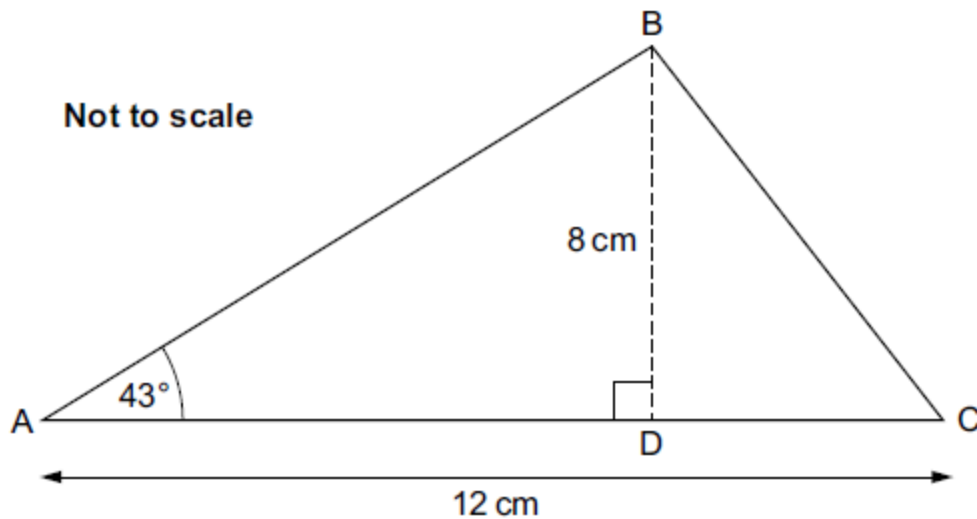

Calculate angle BCA.

..... [6]

7. Given that $\sin 30^\circ = 0.5$,
work out the value of x . (NON CALCULATOR PAPER)

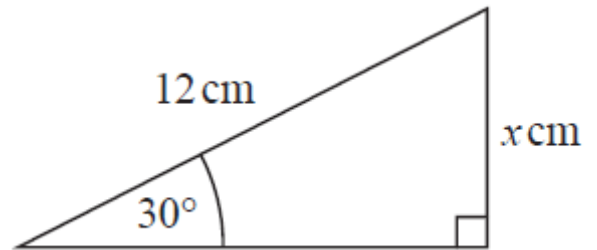

..... [2]

8. (a) Work out the size of angle x .

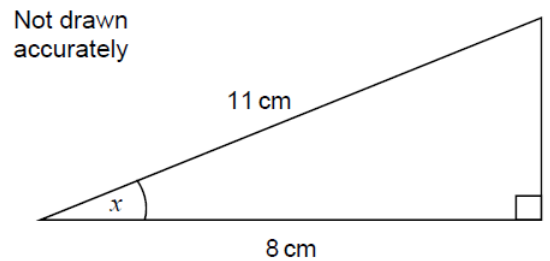

[2]

- (b) Work out length y .

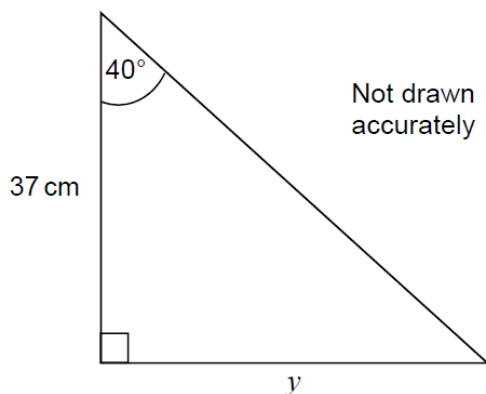

[2]

9. The diagram shows two vertical posts, AB and CD, on horizontal ground.

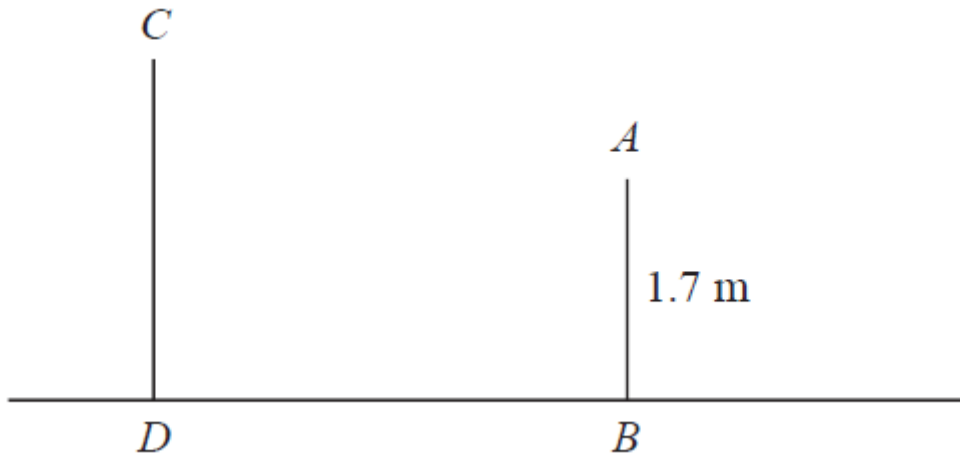

$AB = 1.7 \text{ m}$

$CD : AB = 1.5 : 1$

The angle of elevation of C from A is 52°

Calculate the length of BD.

Give your answer correct to 3 significant figures.

..... m [2]

10. ABC and ABD are two right-angled triangles.

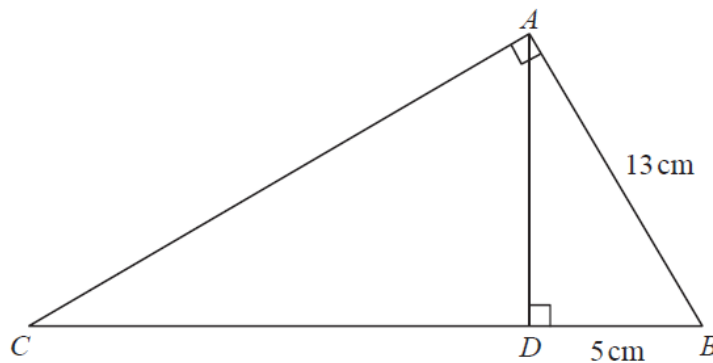

Angle BAC = angle ADB = 90°

$AB = 13 \text{ cm}$

$DB = 5 \text{ cm}$

Work out the length of CB.

..... cm [3]

11. These two right-angled triangles are similar.

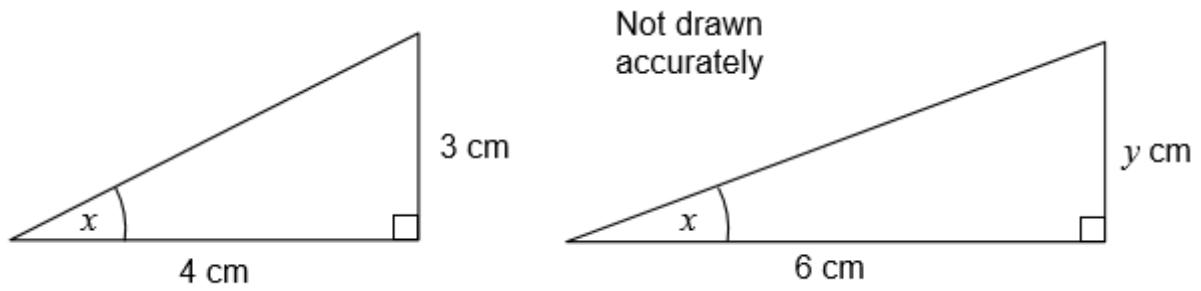

a) Write down the value of $\tan x$. Give your answer as a fraction.

[1]

b) Work out the value of y .

[2]

CREDITS AND NOTES

Q	Awarding Body	Q	Awarding Body	Q	Awarding Body
1	WJEC Eduqas	6	OCR	11	AQA
2	AQA	7	Pearson Edexcel		
3	Pearson Edexcel	8	AQA		
4	AQA	9	Pearson Edexcel		
5	AQA	10	Pearson Edexcel		

Notes:

These questions have been retyped from the original sample/specimen assessment materials and whilst every effort has been made to ensure there are no errors, any that do appear are mine and not the exam board s (similarly any errors I have corrected from the originals are also my corrections and not theirs!).

Please also note that the layout in terms of fonts, answer lines and space given to each question does not reflect the actual papers to save space.

These questions have been collated by me as the basis for a GCSE working party set up by the GLOW maths hub - if you want to get involved please get in touch. The objective is to provide support to fellow teachers and to give you a flavour of how different topics "could" be examined. They should not be used to form a decision as to which board to use. There is no guarantee that a topic will or won't appear in the "live" papers from a specific exam board or that examination of a topic will be as shown in these questions.



Links:

AQA <http://www.aqa.org.uk/subjects/mathematics/gcse/mathematics-8300>

OCR <http://ocr.org.uk/gcsemaths>

Pearson Edexcel <http://qualifications.pearson.com/en/qualifications/edexcel-gcses/mathematics-2015.html>

WJEC Eduqas <http://www.eduqas.co.uk/qualifications/mathematics/gcse/>

Contents:

This version contains questions from:

AQA – Sample Assessment Material, Practice set 1 and Practice set 2

OCR – Sample Assessment Material and Practice set 1

Pearson Edexcel – Sample Assessment Material, Specimen set 1 and Specimen set 2

WJEC Eduqas – Sample Assessment Material