

# Volume of Prisms, Cones, Pyramids & Spheres (H)

A collection of 9-1 Maths GCSE Sample and Specimen questions from AQA, OCR, Pearson-Edexcel and WJEC Eduqas.

Name:	
Total Marks:	

1. A cylinder is made of bendable plastic.  
A dog's toy is made by bending the cylinder to form a ring.

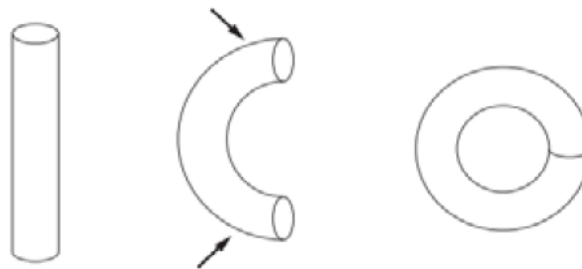
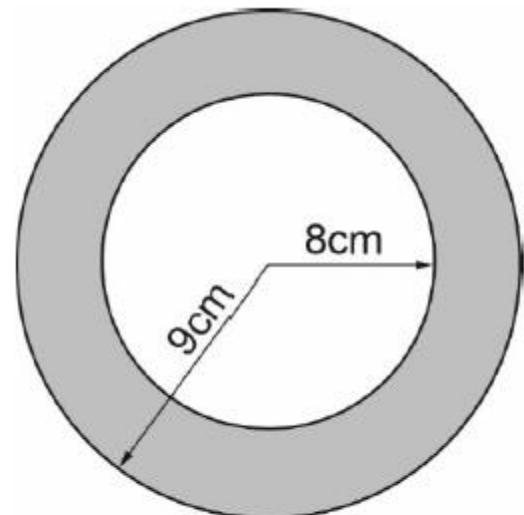

*Diagram not drawn to scale*

The inner radius of the dog's toy is 8 cm.  
The outer radius of the dog's toy is 9 cm.

Calculate an approximate value for the volume of the dog's toy.

State and justify what assumptions you have made in your calculations and the impact they have had on your results.



*Diagram not drawn to scale*

[7]

2. In this question all dimensions are in centimetres.

A solid has uniform cross section.

The cross section is a rectangle and a semicircle joined together.

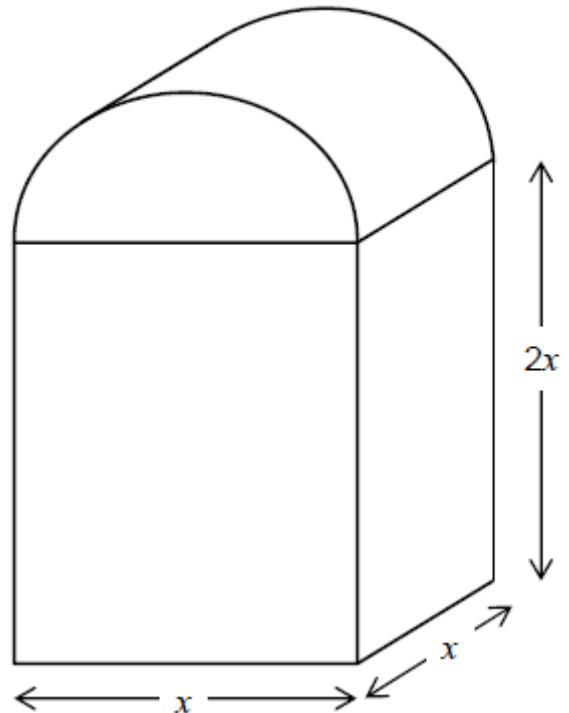

Work out an expression, in  $\text{cm}^3$ , for the total volume of the solid.

Write your expression in the form  $ax^3 + \frac{1}{b}\pi x^3$  where  $a$  and  $b$  are integers.

[4]

3. A circular table top has radius 70 cm.

(a) Calculate the area of the table top in  $\text{cm}^2$ , giving your answer as a multiple of  $\pi$ .

(a) .....  $\text{cm}^2$  [2]

(b) The volume of the table top is  $17\,150\pi \text{ cm}^3$ .

Calculate the thickness of the table top.

(b) ..... cm [2]

4. The volume of Earth is  $1.08 \times 10^{12} \text{ km}^3$ .

The volume of Jupiter is  $1.43 \times 10^{15} \text{ km}^3$ .

How many times larger is the radius of Jupiter than the radius of Earth?

Assume that Jupiter and Earth are both spheres.

The volume  $v$  of a sphere with radius  $r$  is  $V = \frac{4}{3}\pi r^3$

..... [4]

5. A frustum is made by removing a small cone from a large cone as shown in the diagram.

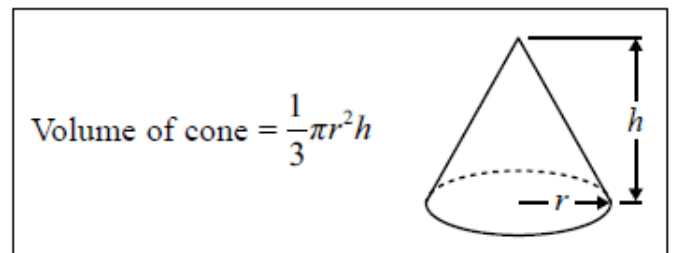
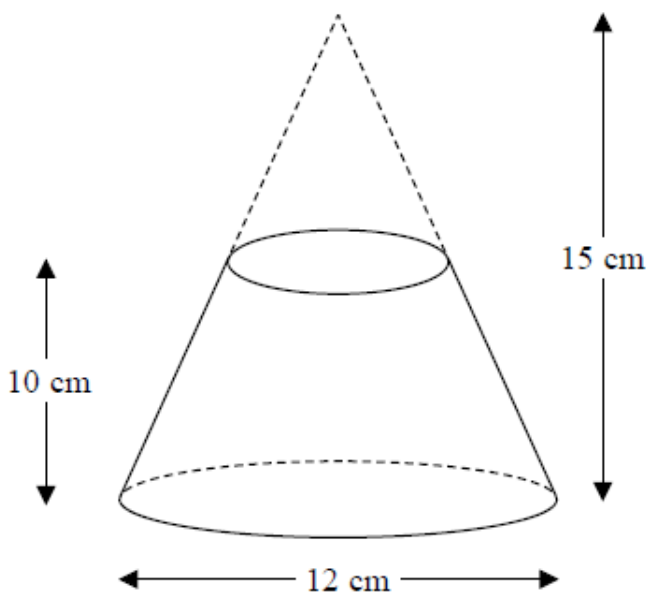

The frustum is made from glass.

The glass has a density of  $2.5 \text{ g / cm}^3$

Work out the mass of the frustum.

Give your answer to an appropriate degree of accuracy.

.....g [4]

6. A bowl is a hemisphere with radius 6 cm

Water fills two-fifths of the volume of the bowl.

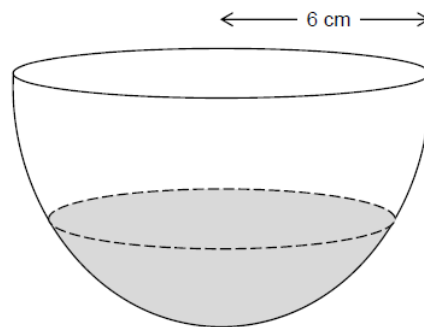

The water is poured into a hollow cone.

The depth of the water in the cone is 12 cm

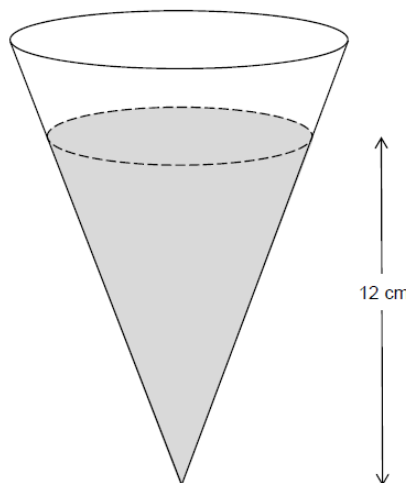

Volume of a sphere =  $\frac{4}{3}\pi r^3$  where  $r$  is the radius.

Volume of a cone =  $\frac{1}{3}\pi r^2 h$  where  $r$  is the radius and  $h$  is the perpendicular height

Work out the radius of the surface of the water in the cone.

[4]

7. The diagram shows a sand pit.

The sand pit is in the shape of a cuboid.  
 Sally wants to fill the sand pit with sand.  
 A bag of sand costs £2.50  
 There are 8 litres of sand in each bag.  
 Sally says,  
 "The sand will cost less than £70"  
 Show that Sally is wrong.

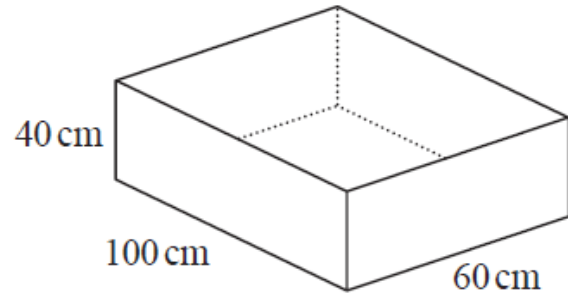

[5]

8. The diagram shows an oil tank in the shape of a prism.

The cross section of the prism is a trapezium.  
 The tank is empty.  
 Oil flows into the tank.  
 After one minute there are 300 litres of oil in the tank.  
 Assume that oil continues to flow into the tank at this rate.

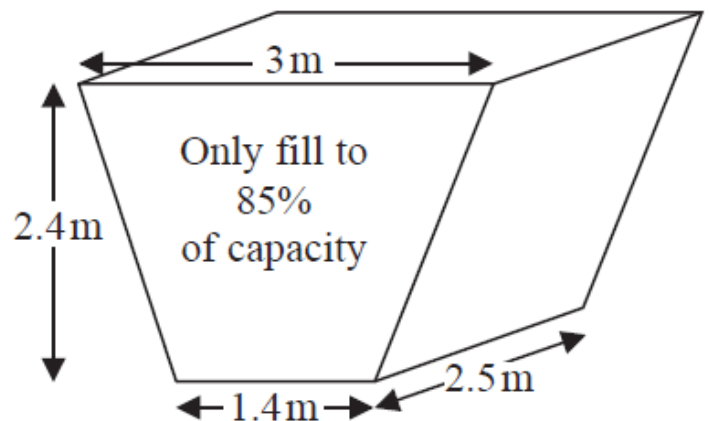

(a) Work out how many more minutes it takes for the tank to be 85% full of oil.  
 ( $1 \text{ m}^3 = 1000 \text{ litres}$ )

..... minutes [5]

The assumption about the rate of flow of the oil could be wrong.

(b) Explain how this could affect your answer to part (a).

[1]

9. A water tank is a cylinder with radius 40 cm and depth 150 cm

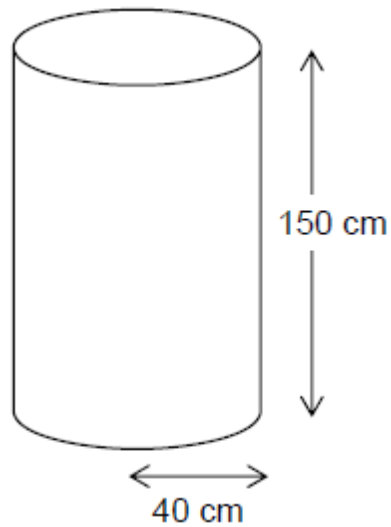

It is filled at the rate of 0.2 litres per second.

1 litre = 1000 cm<sup>3</sup>

Does it take longer than 1 hour to fill the tank?

You must show your working.

[4]

10. Here is a cuboid.

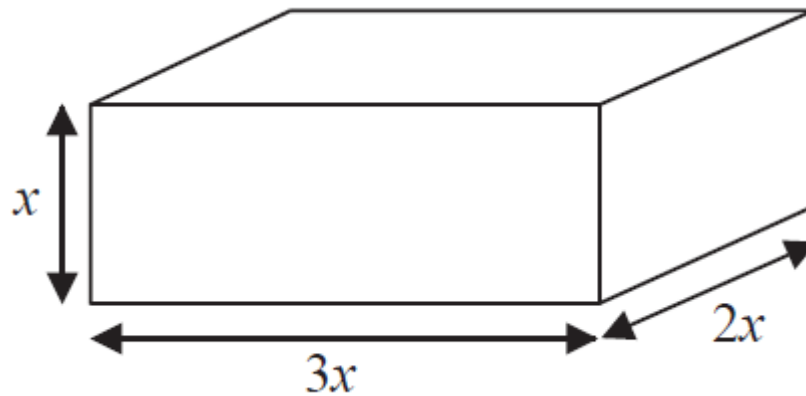

All measurements are in centimetres.

$x$  is an integer.

The total volume of the cuboid is less than  $900 \text{ cm}^3$

Show that  $x \leq 5$

[3]

11. A solid is made by putting a hemisphere on top of a cone.

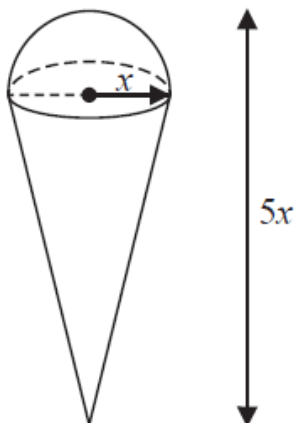

<p><b>Volume of cone</b> = <math>\frac{1}{3}\pi r^2 h</math></p>	
<p><b>Volume of sphere</b> = <math>\frac{4}{3}\pi r^3</math></p>	

The total height of the solid is  $5x$

The radius of the base of the cone is  $x$

The radius of the hemisphere is  $x$

A cylinder has the same volume as the solid.

The cylinder has radius  $2x$  and height  $h$

All measurements are in centimetres.

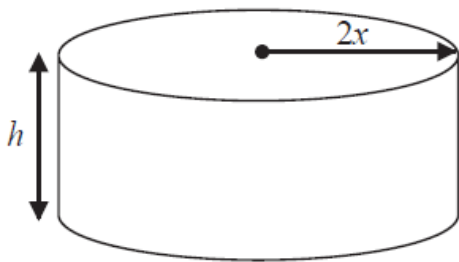

Find a formula for  $h$  in terms of  $x$   
Give your answer in its simplest form.

[5]

12. The diagram shows a solid cone.

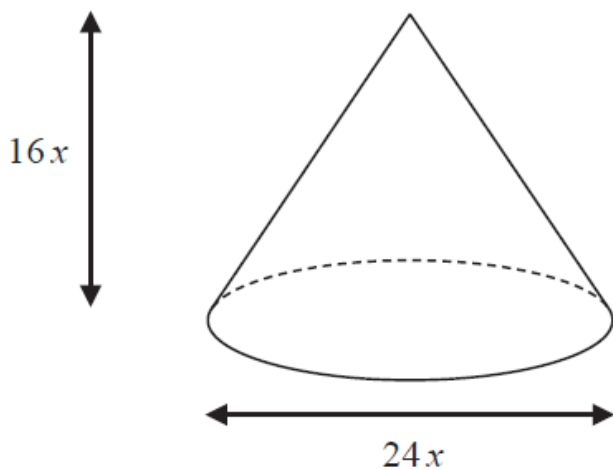

**Volume of cone** =  $\frac{1}{3}\pi r^2 h$

**Curved surface area of cone** =  $\pi r l$

A diagram of a cone with slant height  $l$ , height  $h$ , and radius  $r$ .

The diameter of the base of the cone is  $24x$  cm.

The height of the cone is  $16x$  cm.

The curved surface area of the cone is  $2160\pi$  cm<sup>2</sup>.

The volume of the cone is  $V\pi$  cm<sup>3</sup>, where  $V$  is an integer.

Find the value of  $V$ .

[5]



13. The diagram shows a solid hemisphere.

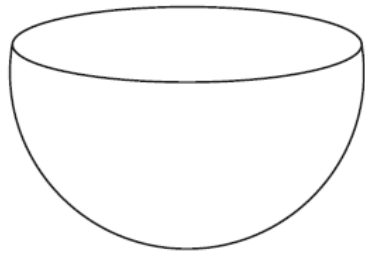

Volume of sphere =  $\frac{4}{3}\pi r^3$   
 Surface area of sphere =  $4\pi r^2$

The volume of the hemisphere is  $\frac{250}{3}\pi$

Work out the exact total surface area of the solid hemisphere.  
 Give your answer as a multiple of  $\pi$ .

..... cm<sup>2</sup> [4]

14. Volume of a pyramid =  $\frac{1}{3}$  x area of base x perpendicular height

*VABCD* is a rectangular-based pyramid with volume 336 m<sup>3</sup>

*X* is the centre of the horizontal base, directly below *V*.

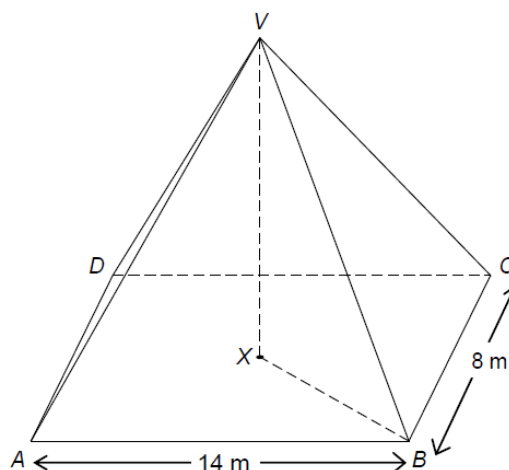

Work out the angle between *VB* and the base.

[6]

15. A solid metal sphere has radius 9.8 cm.

The metal has a density of  $5.023 \text{ g/cm}^3$ .

Lynne estimates the mass of this sphere to be 20 kg.

Show that this is a reasonable estimate for the mass of the sphere.

[The volume  $V$  of a sphere with radius  $r$  is  $V = \frac{4}{3} \pi r^3$  ]

[5]

16. Volume of a sphere =  $\frac{4}{3} \pi r^3$  where  $r$  is the radius.

a) Work out the volume of a sphere of radius 8 cm

[2]

b) Three spheres of radius 8 cm are packed tightly into a cuboid as shown.

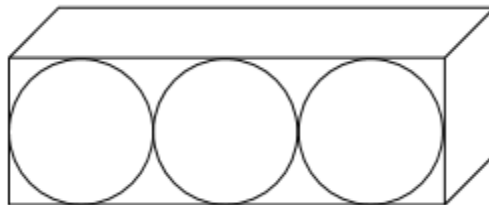

Work out the volume of the cuboid.

[4]

## CREDITS AND NOTES

Question	Awarding Body	Question	Awarding Body
1	WJEC Eduqas	9	AQA
2	AQA	10	Pearson Edexcel
3	OCR	11	Pearson Edexcel
4	OCR	12	Pearson Edexcel
5	Pearson Edexcel	13	Pearson Edexcel
6	AQA	14	AQA
7	Pearson Edexcel	15	OCR
8	Pearson Edexcel	16	AQA

### Notes:

These questions have been retyped from the original sample/specimen assessment materials and whilst every effort has been made to ensure there are no errors, any that do appear are mine and not the exam board s (similarly any errors I have corrected from the originals are also my corrections and not theirs!).

Please also note that the layout in terms of fonts, answer lines and space given to each question does not reflect the actual papers to save space.

These questions have been collated by me as the basis for a GCSE working party set up by the GLOW maths hub - if you want to get involved please get in touch. The objective is to provide support to fellow teachers and to give you a flavour of how different topics "could" be examined. They should not be used to form a decision as to which board to use. There is no guarantee that a topic will or won't appear in the "live" papers from a specific exam board or that examination of a topic will be as shown in these questions.



### Links:

AQA <http://www.aqa.org.uk/subjects/mathematics/gcse/mathematics-8300>

OCR <http://ocr.org.uk/gcsemaths>

Pearson Edexcel <http://qualifications.pearson.com/en/qualifications/edexcel-gcses/mathematics-2015.html>

WJEC Eduqas <http://www.eduqas.co.uk/qualifications/mathematics/gcse/>

### Contents:

This version contains questions from:

AQA – Sample Assessment Material, Practice set 1 and Practice set 2

OCR – Sample Assessment Material and Practice set 1

Pearson Edexcel – Sample Assessment Material, Specimen set 1 and Specimen set 2

WJEC Eduqas – Sample Assessment Material