

# "BEST GUESS" - JUNE 2016

## EDEXCEL LINEAR PAPER 2 (HIGHER)

This paper has been made up of questions for the topics that we believe are worth revising prior to paper 2 (Edexcel Linear) – as with all these things there are **no guarantees** and are our “Best Guess” for all higher tier students. This is meant to act as a practice paper and not meant to emulate the real thing – the order of the questions are not intended to act as a guide as to the level of difficulty so aim to have a go at every question.

In addition to this there are some “top end topics” you’ll need to revise if you are aiming for grades A/A\* but the below are the ones that you need to “nail” on your final paper. Good Luck

	Marks	Actual	  
1. Use of Calculator	3		
2. Translations	2		
3. Stem and leaf	5		
4. Ratio	3		
5. Standard Form	3		
6. Depreciation	3		
7. Scatter Graphs	4		
8. Averages from a table	4		
9. Angle facts	4		
10. Product of prime factors	3		
11. Averages	3		
12. Surface area	4		
13. Exchange Rates	3		
14. Pie Charts	4		
15. Inequalities	5		
16. Bearings and trigonometry	7		
17. Sequences and $n$ th term	4		
18. Plans and elevations	2		
19. Angles in polygons	3		
20. Pythagoras Theorem	3		
21. Compound Interest	3		
22. Straight line graphs	4		
23. Best Value	3		
24. Estimate of the mean/Frequency polygons	7		
25. Trial & Improvement	4		
26. Proportion recipes	4		
27. Forming & Solving equations	4		
28. Reciprocal Graphs	4		
29. Rotations & Reflections	3		
30. Enlargements	3		
31. Trigonometry	4		
32. Pythagoras & Trig	4		
33. Multiples in Context	4		
34. Similar Shapes	4		
35. Histograms	5		
36. Cumulative Frequency	4		
TOTAL	136		

**Q1.** Use your calculator to work out  $\sqrt{\frac{920 - 170 \tan 65^\circ}{0.012 + 0.034}}$

Write down all the figures on your calculator display.  
You must give your answer as a decimal.

..... (2)

(a) Give your answer to part (a) correct to 4 significant figures.

..... (1)

**Q2.**

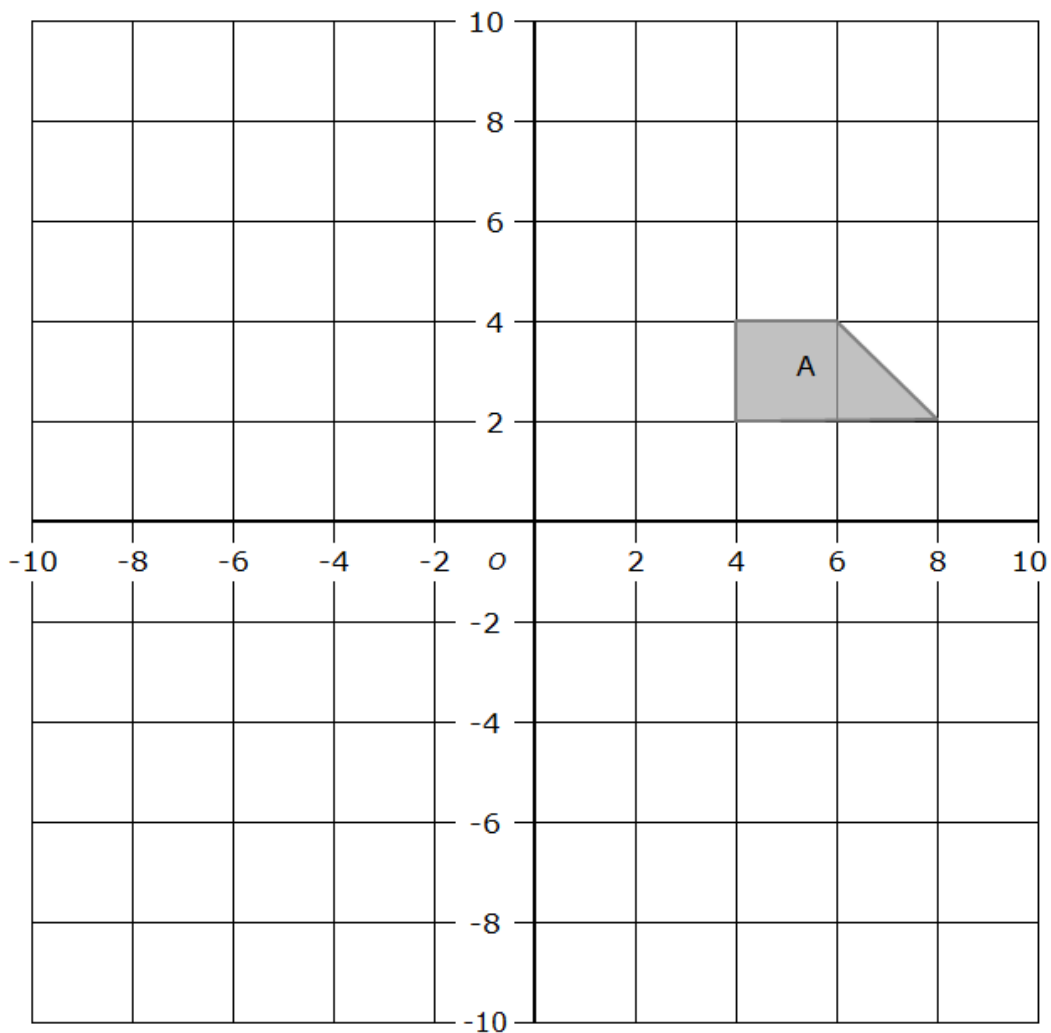

Translate shape A by  $\begin{pmatrix} -8 \\ -2 \end{pmatrix}$

Label the new shape **B**.

(2)

**Q3.** Use the stem and leaf diagram to find the below information

1	3 5 7 7
2	0 6 8 8 8 9
3	1 5 5 5 5 6 8 9
4	1 5
5	2

Key: 5 | 2 means 5.2 cm

- (a) What is the mode. .... cm (1)
- (b) Work out the median. .... cm (2)
- (c) Work out the interquartile range. .... cm (2)

**Q4.** Mel, Emma and Hannah share some money in the ratio 5:9:6  
Mel and Emma share £56. How much does Hannah get?

(3)

**Q5.**

- (i) Write  $8.411 \times 10^{-3}$  as an ordinary number. (1)
- (ii) Write 501 in Standard Index Form. (1)
- (iii) Write  $10.9 \times 10^4$  in Standard Index Form (1)

**Q6.** The value of a second hand car is £6000  
Each year it loses 20% of its value  
Work out its value in 2 years time.

(3)

- Q7** Dawn reads eight books. For each book she records the number of pages and the time she takes to read it. The scatter graph shows information about her results.

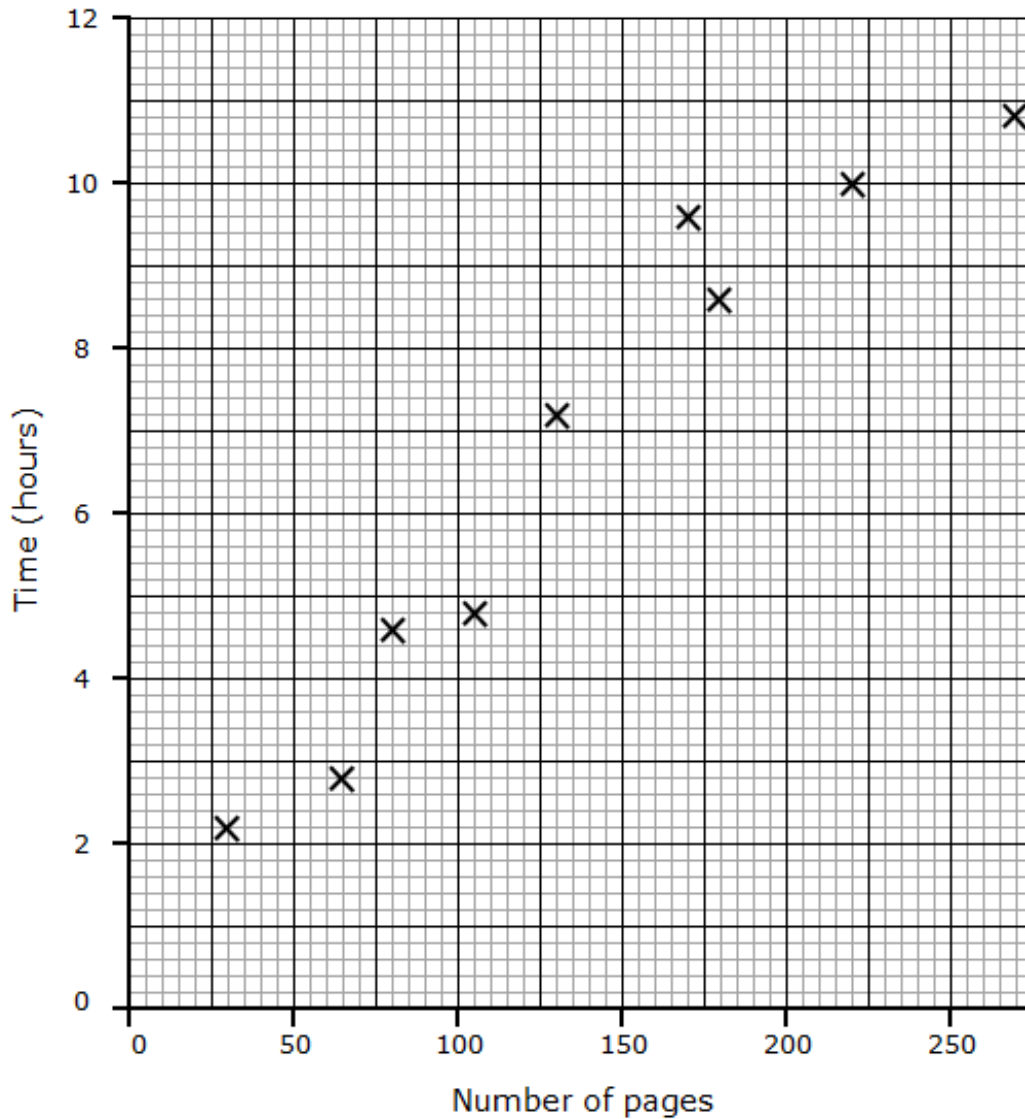

- a) Dawn reads another book with 185 pages and it takes her 9 hours to read the book. Plot this on the graph.

(1)

- b) Describe the relationship between the number of pages in a book and the time Dawn takes to read it.

(1)

- c) Dawn reads another book. The book has 150 pages. Estimate the time it takes Dawn to read it.

(2)

**Q8.** Lois asked 32 women about the number of children they each had.

The table shows information about her results.

Number of children	Frequency
0	9
1	6
2	7
3	8
4	2
More than 4	0

a) Find the mode

(1)

b) Calculate the mean

(3)

**Q9.** ABCD is a parallelogram.

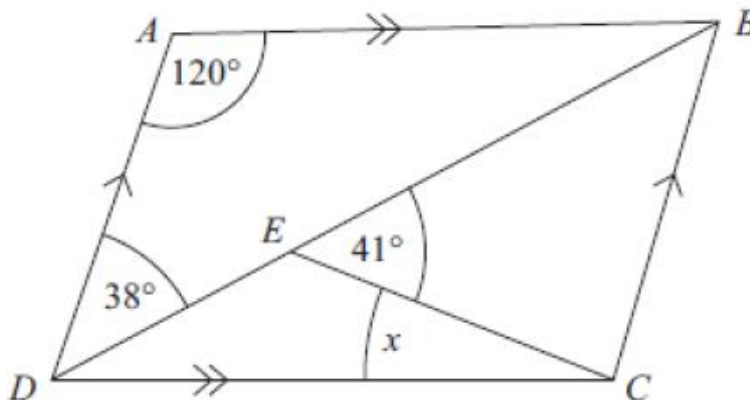

Angle ADB =  $38^\circ$ .

Angle BEC =  $41^\circ$ .

Angle DAB =  $120^\circ$ .

Calculate the size of angle  $x$ .

You must give reasons for your answer.

(4)

**Q10.** The number 1104 can be written as  $3 \times 2^c \times d$ , where  $c$  is a whole number and  $d$  is a prime number. Work out the values of  $c$  and  $d$

(3)

**Q11.** Hertford Juniors is a basketball team.

At the end of 10 games, their mean score is 35 points per game.

At the end of 11 games, their mean score has gone down to 33 points per game.

How many points did the team score in the 11th game? show your working out.

(3)

**Q12.** Work out the total surface area of the triangular prism.

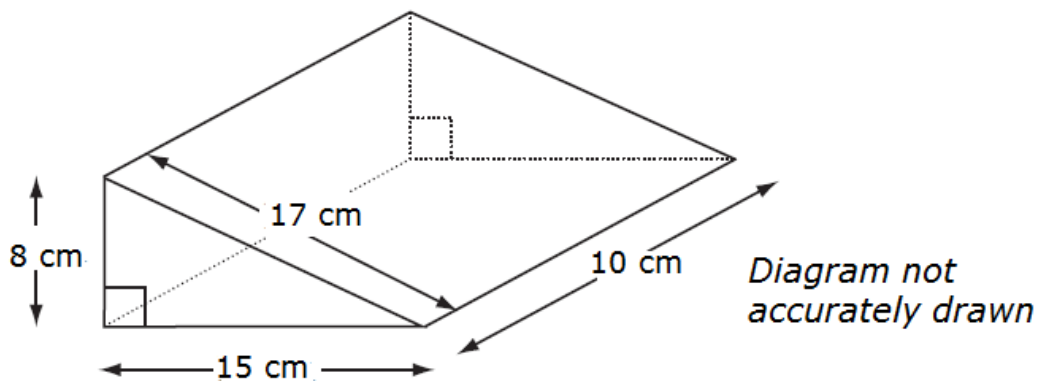

(4)

**Q13.** The exchange rate in London is  $\text{£}1 = \text{€}1.14$

The exchange rate in Paris is  $\text{€}1 = \text{£}0.86$

Robert wants to change some pounds into euros.

In which of these cities would Robert get the most euros? You must show all your working.

..... (3)

**Q14.** The pie chart shows information about Mel's spending last month. The pie chart is accurately drawn.

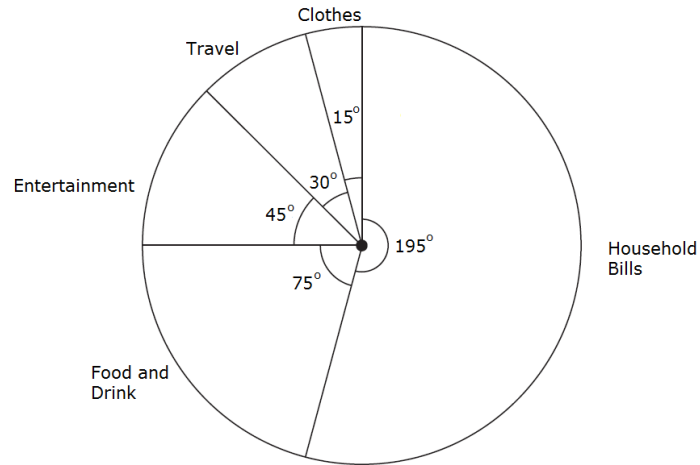

a) Mel spent £80 on travel last month. Work out the amount spent on household bills.

(2)

b) A second pie chart is to be drawn from Karen's spending.

Karen spent a total of £800 last month.

She spent £120 on entertainment last month.

Calculate the size of the angle for entertainment in the second pie chart.

(2)

**Q15.** (i)  $n$  is an integer.

$$-1 \leq n < 4$$

List the possible values of  $n$ .

(2)

(ii)

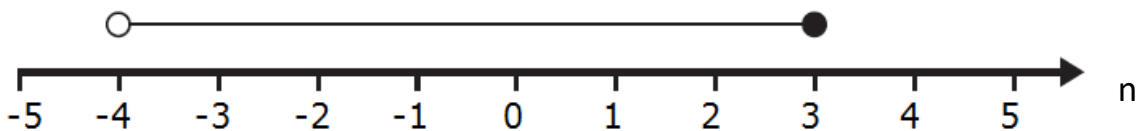

Write down the inequality shown in the diagram.

(2)

(iii) On the number line, show the inequality  $-2 < y < 3$

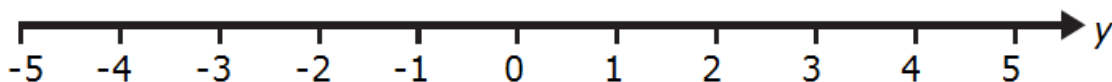

(1)

**Q16.** The diagram shows the positions of three turbines A, B and C.

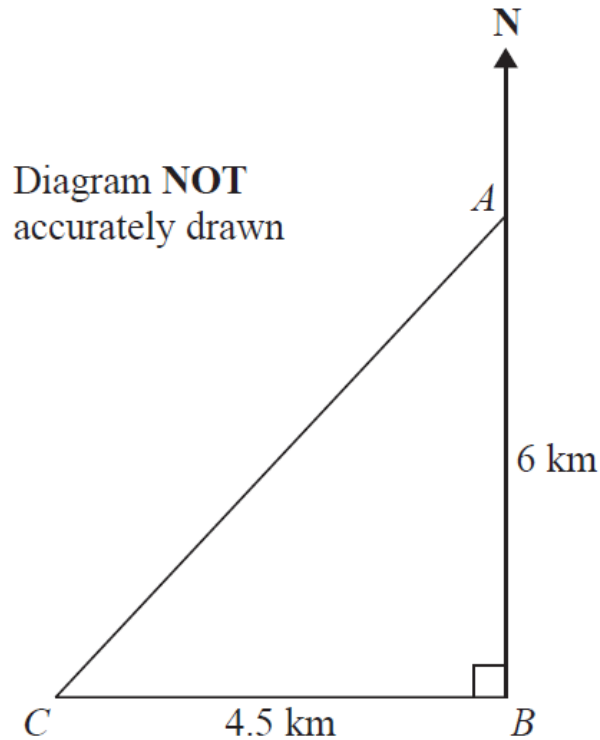

A is 6 km due north of turbine B.

C is 4.5 km due west of turbine B.

(a) Calculate the distance AC.

..... km (3)

(b) Calculate the bearing of C from A.

Give your answer correct to the nearest degree.

.....° (4)

**Q17.** Here are the first five terms of an arithmetic sequence.

2      6      10      14      18

a) Find, in terms of  $n$ , an expression for the  $n$ th term of this sequence.

(2)

b) An expression for the  $n$ th term of another sequence is  $10 - n^2$

Find the third term and the fifth term of this sequence.

(2)



**Q18.** Here are the front elevation, side elevation and the plan of a 3-D shape.

In the space below, draw a sketch of the 3-D shape.



Front elevation

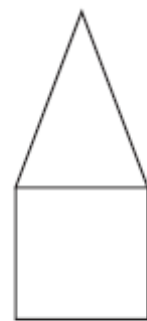

Side elevation

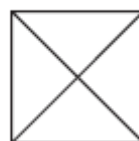

Plan

(2)

**Q19.** The diagram shows a regular hexagon and a regular octagon.

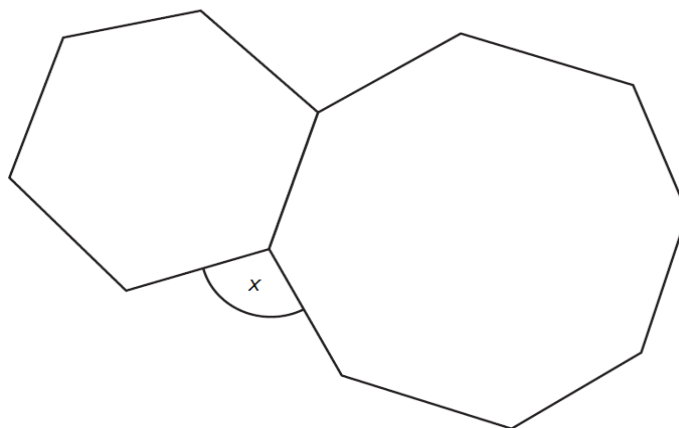

Calculate the size of the angle marked  $x$

You must show all your working.

(3)

**Q20.** ABCD is a rectangle.

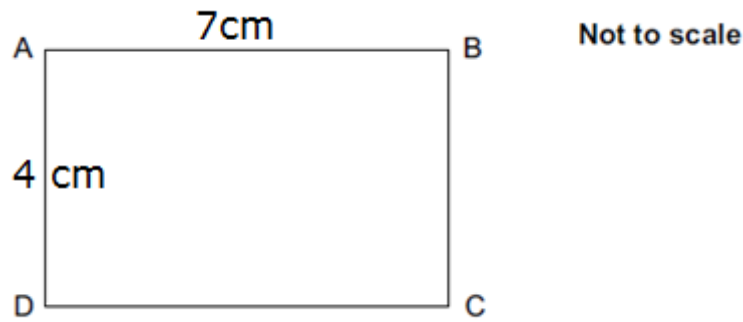

(a) Laura calculates the length of AC, but gets it wrong.

$$7^2 - 4^2 = AC^2$$

$$\sqrt{33} = AC$$

$$\sqrt{33} = 5.7 \text{ (to 1 decimal place)}$$

$$AC = 5.7 \text{ (to 1 decimal place)}$$

Explain what Laura has done wrong.

[1]

(b) Calculate the length of AC.

..... m [2]

**Q21.** £650 is invested in a bank account for 2 years at 1.5% compound interest per year.

How much is in the account at the end of the 2 years?

(3)

**Q22.** Use the grid below to draw the graph of the straight line  $y = 8 - 4x$  between  $x = 0$  and  $x = 4$

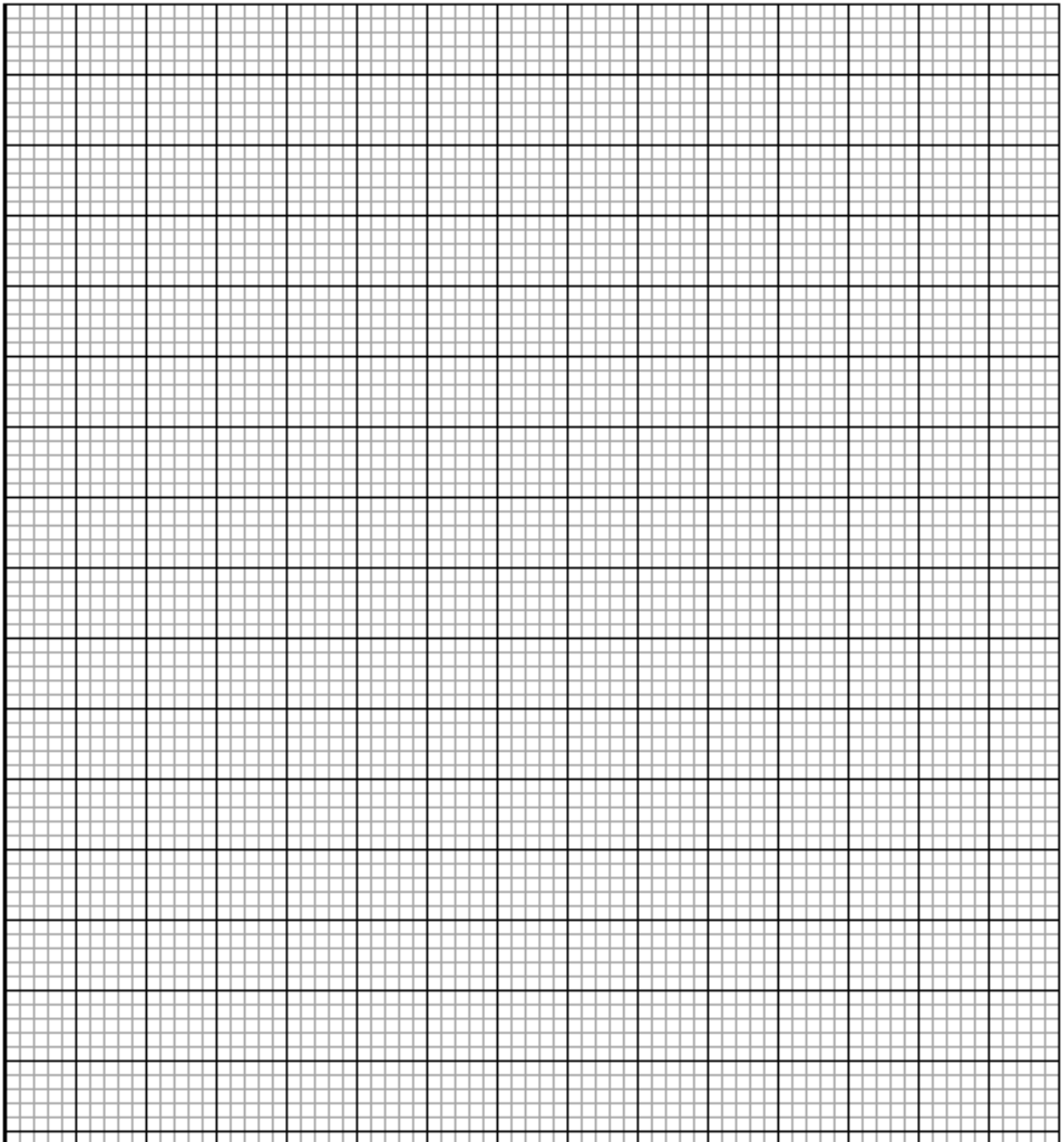

(4)

**Q23.** Soap powder is sold in three different sizes of box.

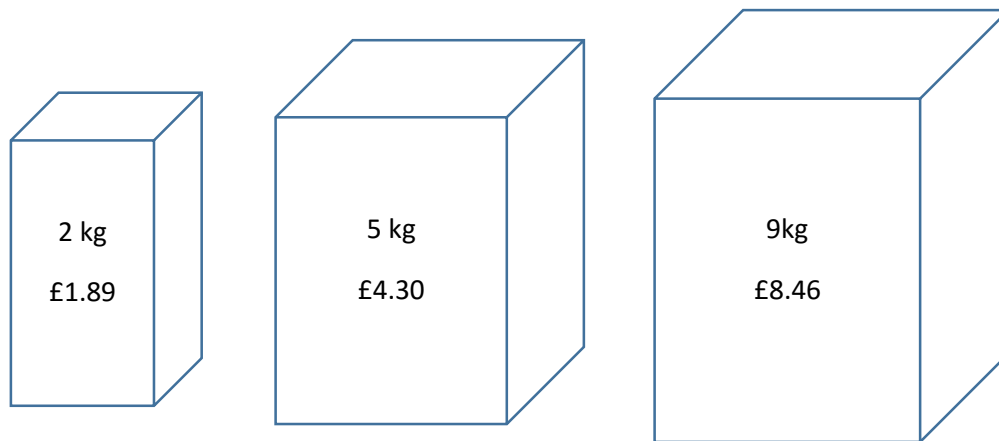

A 2 kg box of soap powder is £1.89  
A 5 kg box of soap powder is £4.30  
A 9 kg box of soap powder is £8.46

Work out which size of box of soap powder gives the best value for money.  
You must show how you get your answer.

**(3)**

**Q24.** The table gives information about the temperature,  $T$  °C, at noon in a town for 60 days.

Temperature ( $T$ °C)	Frequency
10 - 13	7
14 - 17	9
18 - 21	16
22 - 25	22
26 - 29	6

a) Write down the class interval in which the median lies.

..... (1)

b) Calculate an estimate for the mean temperature.

..... °C (4)

c) Draw a frequency polygon for the information in the table.

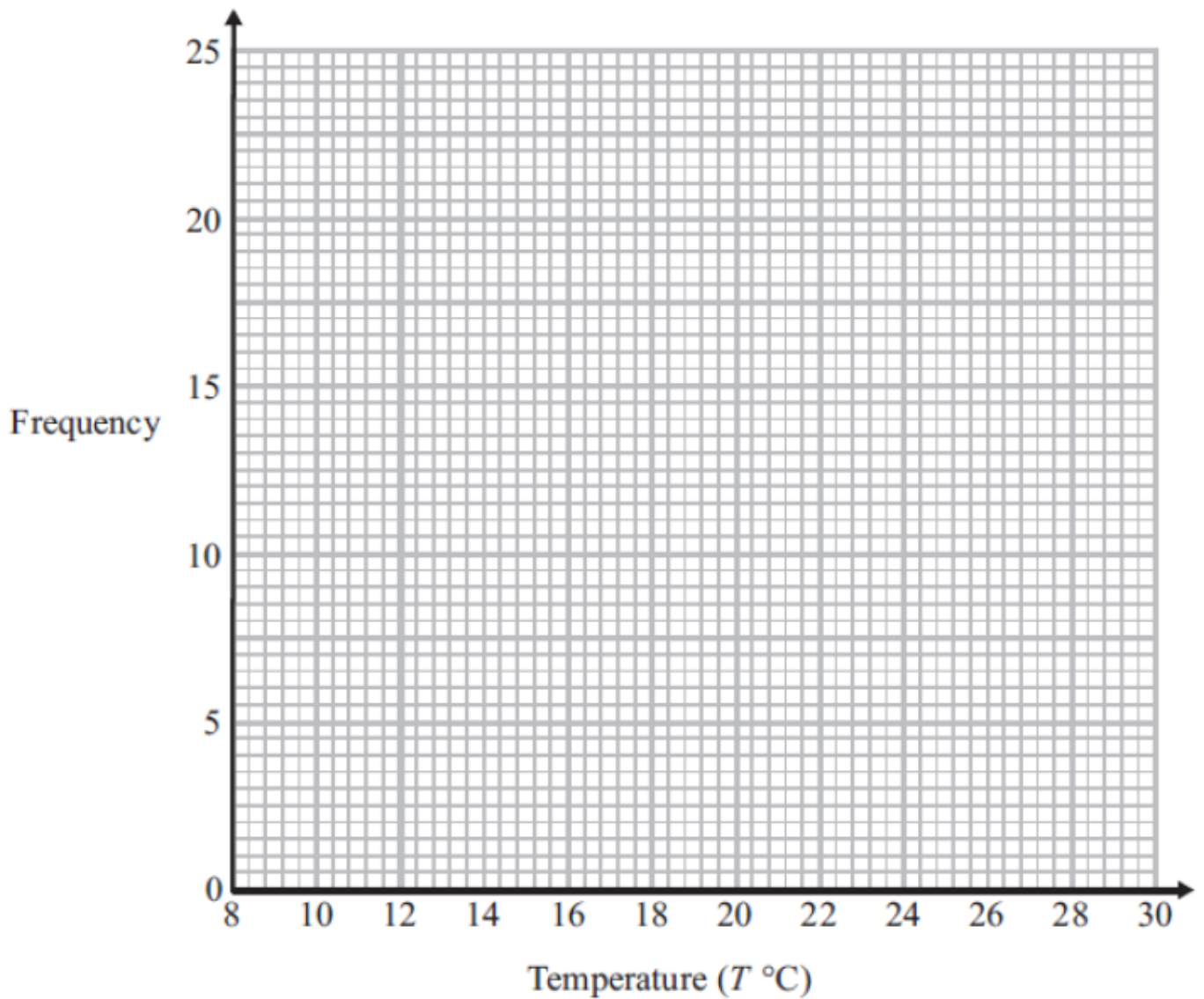

(2)

**Q25.** Use trial and improvement to solve this problem :  $x^3 - 2x = 7$

Give your answer to 1 decimal place.

Show all your trials and their outcomes.

(4)

**Q26.** The table shows the ingredients needed to make vegetable soup for 4 people.

Vegetable soup (serves 4 people)	
Vegetables	600 g
Stock	400 ml
Oil	3 tablespoons
Garlic	2 cloves

a) What weight of vegetables is needed to make vegetable soup for 3 people?

(1)

b) How many tablespoons of oil are needed to make vegetable soup for 6 people?

(1)

c) Matt has only 1 litre of stock. He has plenty of other ingredients. What is the maximum number of people he can make vegetable soup for?

(2)

**Q27.** The diagram shows a trapezium.

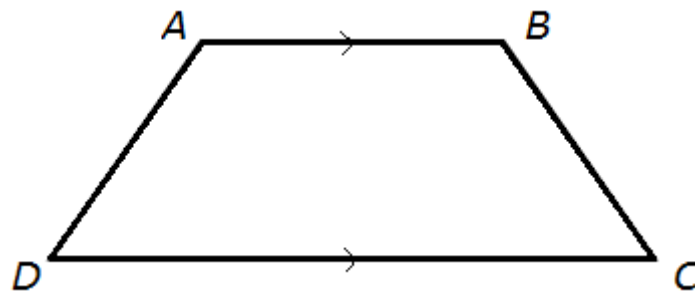

$AD = x$  cm.

$BC$  is the same length of  $AD$ .

$AB$  is the twice the length of  $AD$ .

$DC$  is 4 cm longer than  $AB$ .

The perimeter of the trapezium is 38 cm.

Work out the length of  $AD$ .

(4)

**Q28.** Complete the table of values for  $y = \frac{6}{x}$

x	0.5	1	2	3	4	5	6
y		6	3		1.5		1

(2)

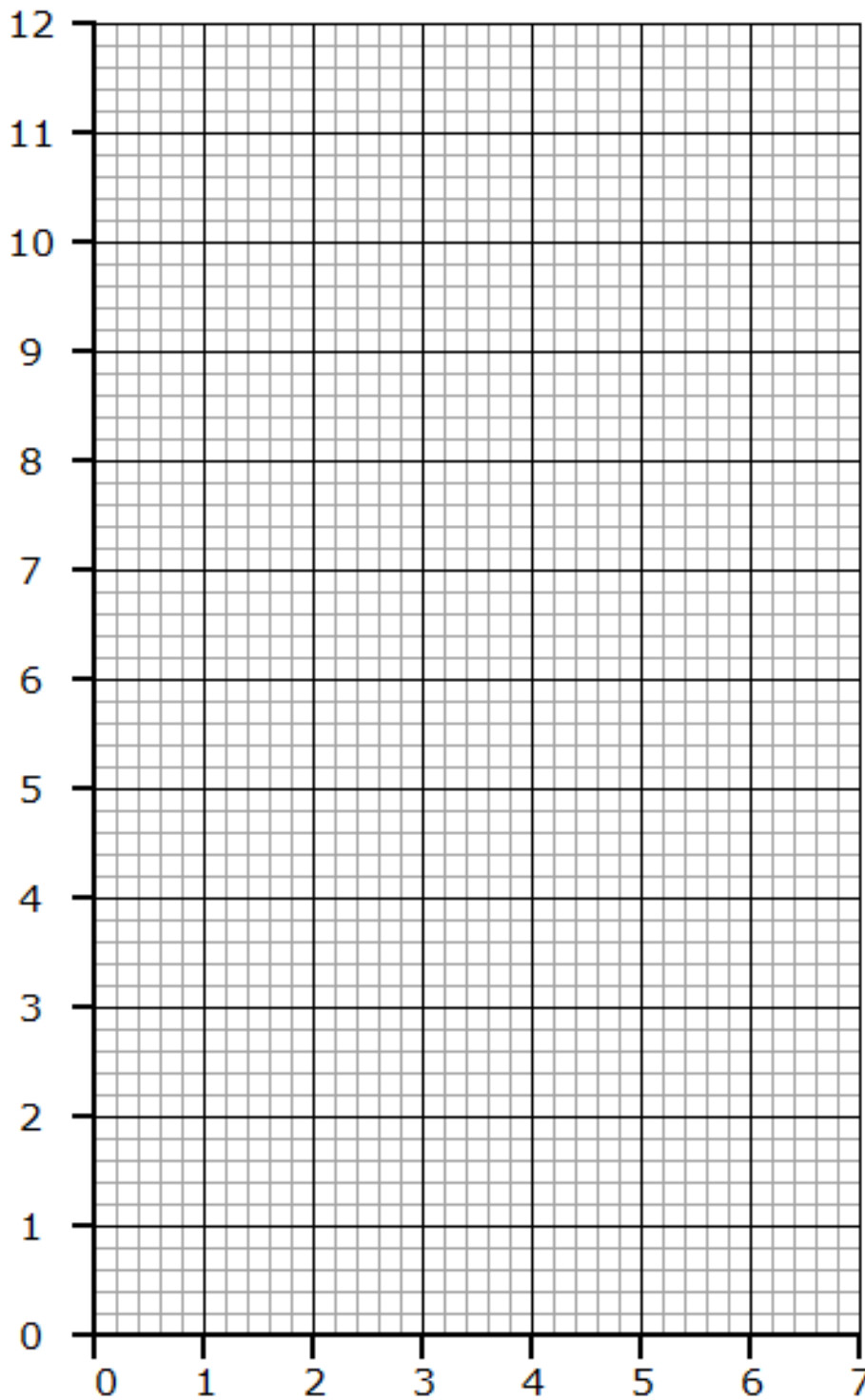

a) On the grid, draw the graph of  $y = \frac{6}{x}$  for  $0.5 \leq x \leq 6$

(2)

**Q29.**

Triangle **P** is drawn on a coordinate grid.

Triangle **P** is reflected in the line  $x = -1$  and then reflected the line  $y = 1$  to give triangle **Q**.

Describe fully the single transformation which maps triangle **P** onto triangle **Q**.

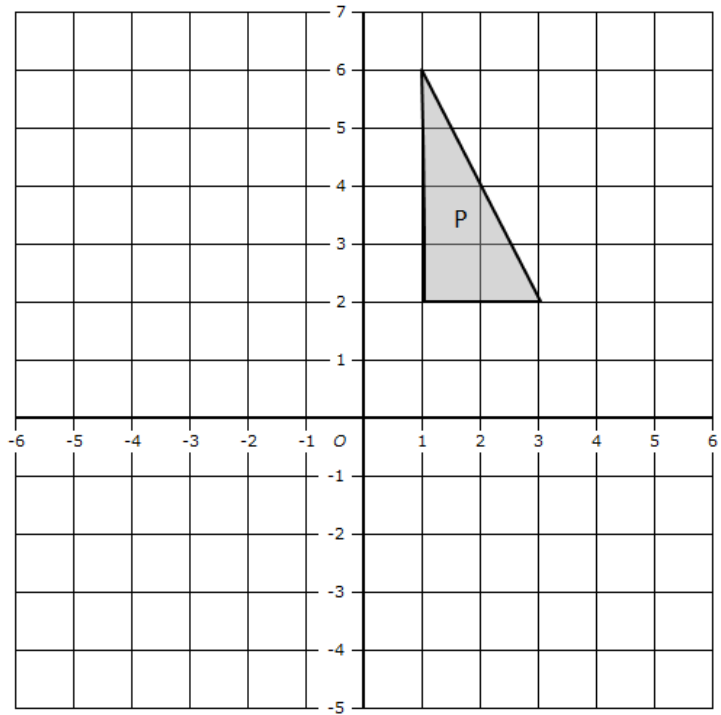

(3)

**Q30.**

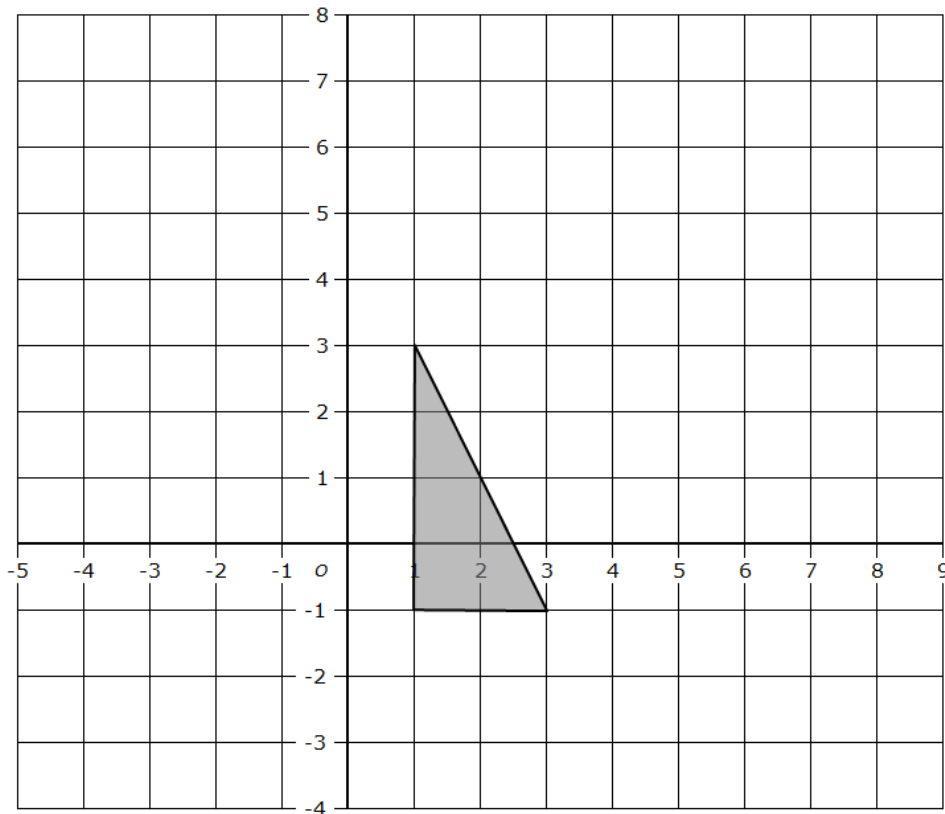

Enlarge the shaded triangle by a scale factor  $\frac{1}{2}$  centre  $(-3, 3)$ .

(3)



**Q31** A man is working out the height of a vertical tree.

The man is able to measure the angle of elevation of the top of the tree from his measuring instrument.

The measuring instrument is 1.8m above ground level.

When the man is standing 19m from the base of the tree, the angle he measures is  $56^\circ$ .

A sketch of this situation is shown below.

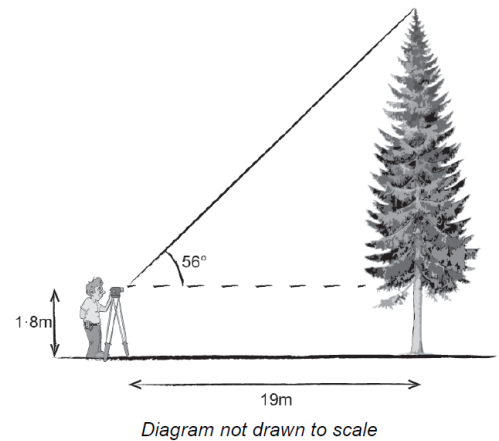

Calculate the full height of the tree.

[4]

**Q32.** The diagram shows a quadrilateral ABCD.

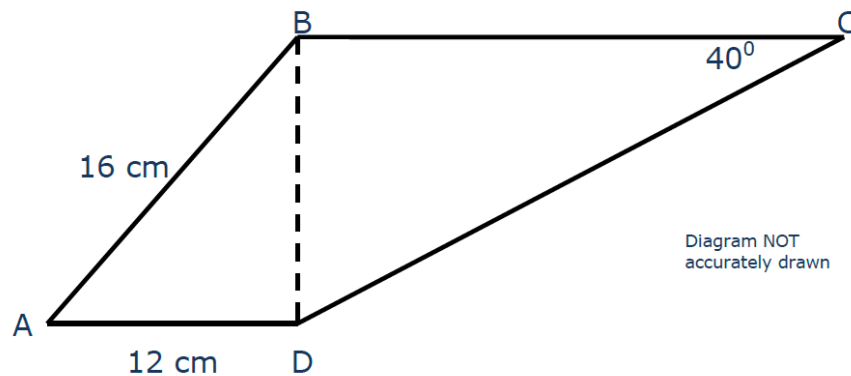

$AB = 16 \text{ cm}$ .

$AD = 12 \text{ cm}$ .

Angle  $BCD = 40^\circ$ .

Angle  $ADB = \text{angle } CBD = 90^\circ$ .

Calculate the length of CD.

Give your answer correct to 3 significant figures.

(5)

**Q33.** Lisa is planning a party.

She wants to buy some cakes and some sausage rolls.

The cakes are sold in boxes.

There are 12 cakes in each box.

Each box of cakes costs £2.50

The sausage rolls are sold in packs.

There are 8 sausage rolls in a pack.

Each pack of sausage rolls costs £1.20

Lisa wants to buy more than 60 cakes and more than 60 sausage rolls. She wants to buy exactly the same number of cakes as sausage rolls.

What is the least amount of money Lisa will have to pay?

(4)

**Q34**

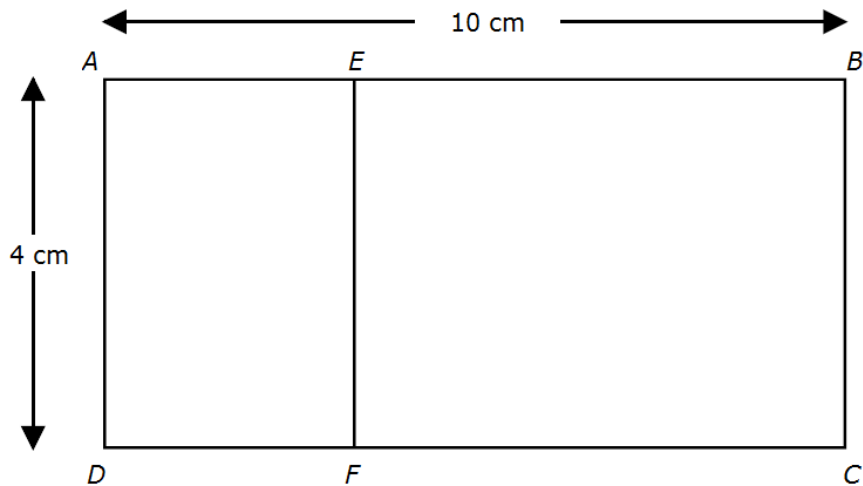

Rectangle  $ABCD$  is mathematically similar to rectangle  $DAEF$

$$AB = 10 \text{ cm}$$

$$AD = 4 \text{ cm}$$

Work out the area of rectangle  $DAEF$ .

(4)

**Q36.** The histogram shows the times taken by people in a group to answer 10 general knowledge questions.

Frequency density

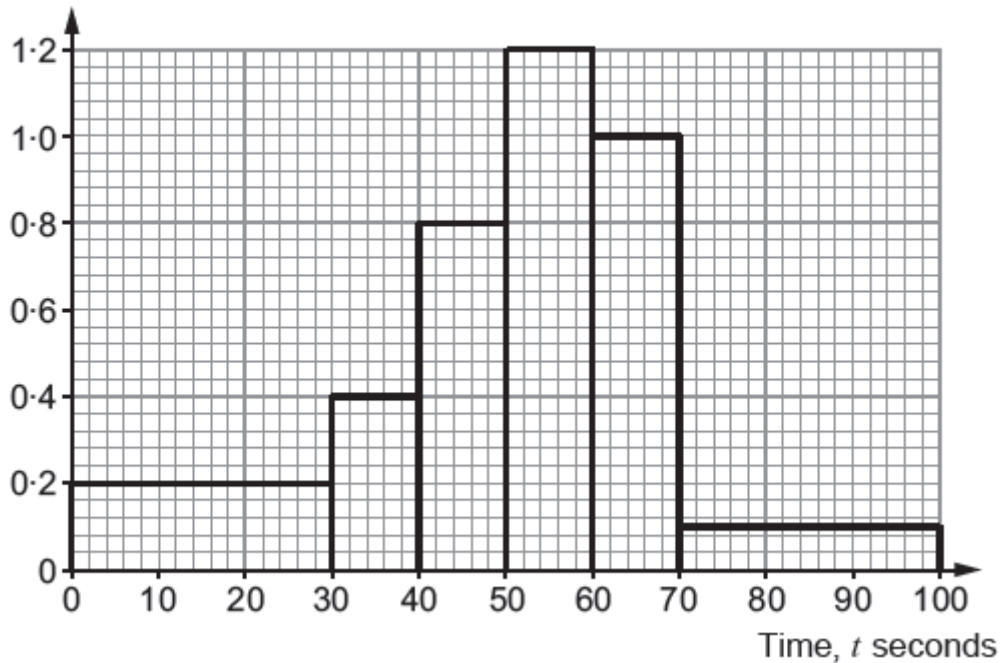

a) Calculate the number of people in the group.

(3)

a) Calculate an estimate for the number of people who answered the questions in less than 65 seconds.

(2)

**Q37.** There are 200 workers at a factory. The cumulative frequency table gives information about their ages.

Age ( $a$ years)	Cumulative frequency
$0 < a \leq 20$	25
$0 < a \leq 30$	70
$0 < a \leq 40$	138
$0 < a \leq 50$	175
$0 < a \leq 60$	186
$0 < a \leq 70$	194
$0 < a \leq 80$	200

(a) On the grid opposite, draw a cumulative frequency graph for this information.

(2)

(b) Graham says: "10% of workers at the factory are older than 65"

Is Graham correct?

You must show how you get your answer.

(2)

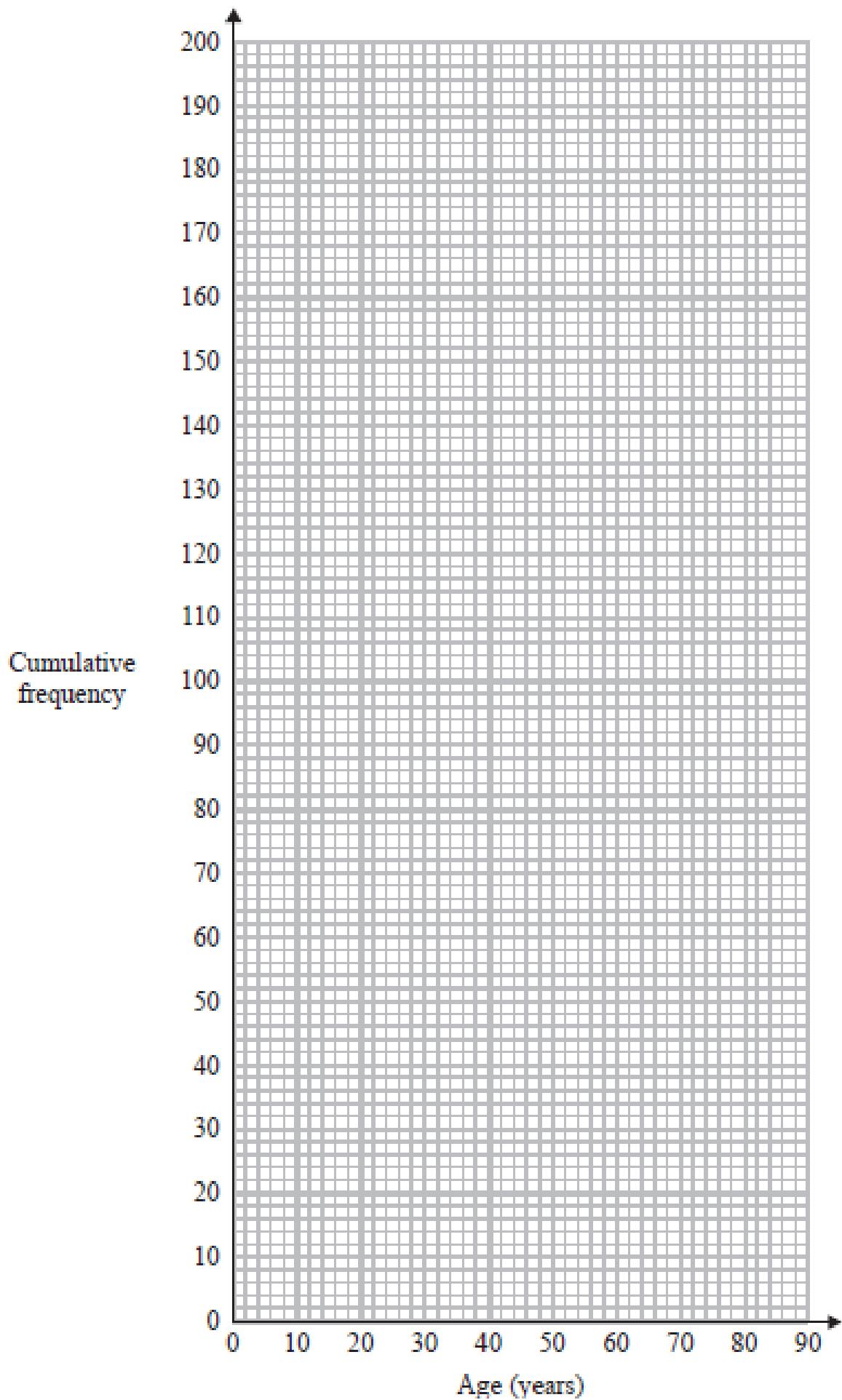

END OF QUESTIONS