

BUMPER
"BETWEEN PAPERS (2 & 3)"
PRACTICE
SUITABLE FOR BOTH FOUNDATION & HIGHER TIERS

SUMMER 2019
QUESTIONS

NOT A "BEST" GUESS PAPER.

**NEITHER IS IT A "PREDICTION" ... ONLY THE EXAMINERS KNOW WHAT IS GOING TO COME UP! FACT!
YOU ALSO NEED TO REMEMBER THAT JUST BECAUSE A TOPIC CAME UP ON PAPER 1 OR 2 IT MAY STILL
COME UP ON PAPER 3 ...**

**WE KNOW HOW IMPORTANT IT IS TO PRACTISE, PRACTISE, PRACTISE SO WE'VE COLLATED A LOAD OF
QUESTIONS THAT WEREN'T EXAMINED IN THE OCR 9-1 GCSE MATHS PAPER 1 OR 2 BUT WE CANNOT
GUARANTEE HOW A TOPIC WILL BE EXAMINED IN THE NEXT PAPER ...**

ENJOY!
MEL & SEAGER

Q1. The diagram shows three points, A , B and C , on a centimetre grid.

(a) Write down the coordinates of

(i) A ,
(.....,))

(ii) B .
(.....,))

(2)

(b) (i) On the diagram, mark with a cross (\times) the point D so that $ABCD$ is a rectangle.

Label your point D .

(ii) On the diagram, draw rectangle $ABCD$.
(2)

(c) Write down the order of rotational symmetry of rectangle $ABCD$.

.....
(1)

(d) Find the coordinates of the midpoint of AB .

(.....,))

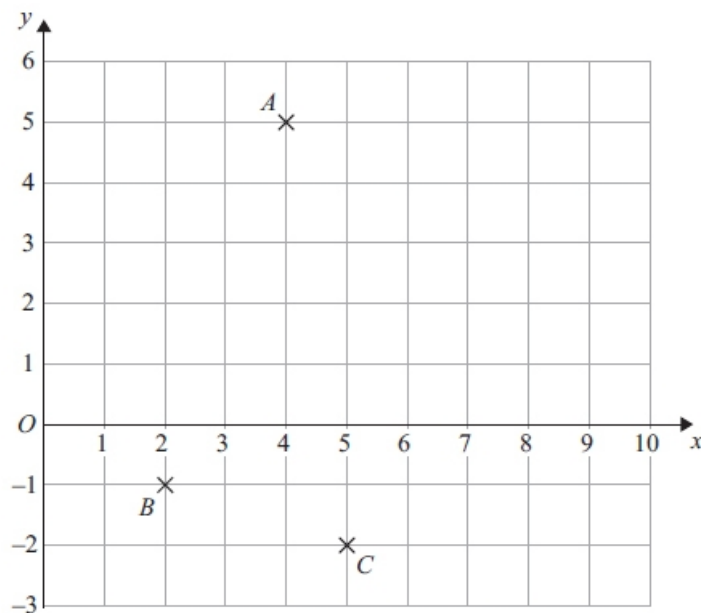

(2)

Q2. (a) Simplify $5c - 6d - 2c + 4d$

(2)

(b) Solve $4x + 5 = 17$

(2)

Q3. The diagram shows points A , B and C on a square grid.

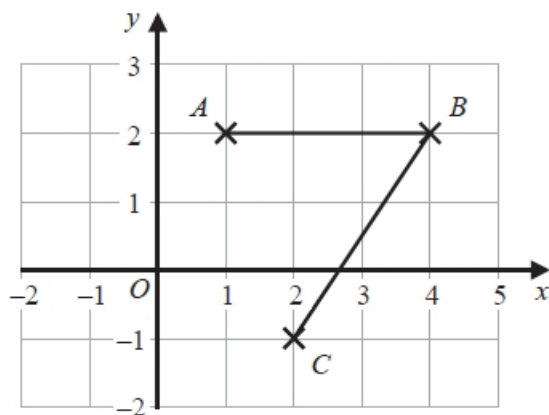

(a) Write down the coordinates of C .

(.....,))

(1)

(b) Measure the length of BC . Give your answer in centimetres.

(1)

(c) On the grid, mark with a cross (\times) the point D so that $ABCD$ is a parallelogram.

Label this point D .

(1)

Q4. (a) Write down the value of the 3 in the number 7.432

(1)

(b) Round 7.432 to the nearest whole number.

(1)

(c) Write down the number which is exactly halfway between 0.7 and 0.8

(1)

(d) Write these numbers in order of size.
Start with the smallest number.

0.14 0.35 0.4 0.07 0.306

(1)

(e) Write 0.31 as a fraction.

(1)

Q5. From the numbers in the box, write down

(i) the square number

2	8	9	27	40	56
---	---	---	----	----	----

(ii) the multiple of 7

(2)

Q6. Express 825 as a product of its prime factors.

(3)

Q7. The diagram shows a parallelogram $PQRS$ drawn on a centimetre grid.

(a) Measure the length of PQ .

..... cm

(b) Write down the coordinates of the point R .

(.....,)
(1)

(c) Work out the area of the parallelogram $PQRS$.
Give the units of your area.

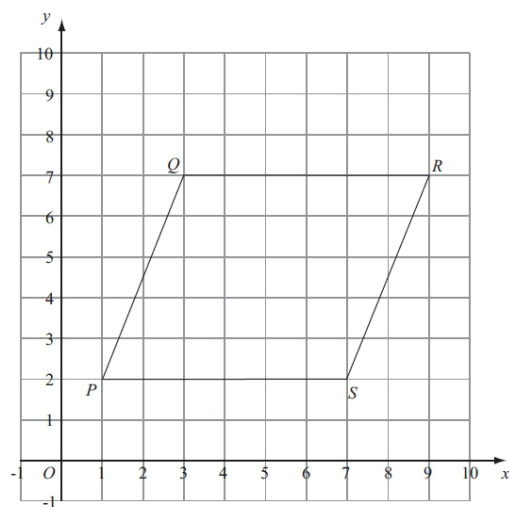

(3)

Q8.(a) Simplify $4x + 3x$

(1)

(b) Simplify $5 \times 3y$

(1)

$$f = 5p - 4v$$

(c) (i) $p = -4, v = 3$

Work out the value of f .

(ii) $f = -22, v = -5$

Work out the value of p .

(5)

Q9.(a) $A = 2^2 \times 3 \times 5^2$ $B = 2^3 \times 5$

(i) Find a common factor of A and B .

(ii) Find a common multiple of A and B .

(3)

(b) $\frac{8^2 \times 8^3}{8^4} = 2^n$

Find the value of n .

(2)

Q10. The diagram shows a shape drawn on a centimetre grid.

(a) On the shape, mark with crosses (x) a pair of perpendicular lines.

(1)

(b) On the shape, mark an obtuse angle. Label your angle A.

(1)

(c) Write down the coordinates of the point P .

(.....,) (1)

(d) Write down the equation of the line PQ .

.....

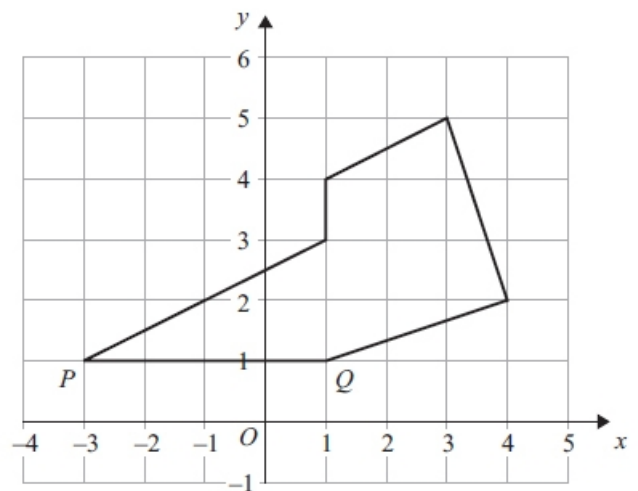

(1)

(e) Find the area of the shape. Give the units of your area.









(3)

Q11. Calvin asked some teachers how many children they have.

The table shows information about his results.

Number of children	0	1	2	3
Number of teachers	8	24	16	10

Calvin started to draw a pictogram for the information in the table. He showed the information for teachers with 0 and 1 child.

Number of children						
0						
1						
2						
3						

(a) How many teachers does  represent?

(1)

(b) Complete the pictogram for the information in the table.

(2)

(c) Find the total number of teachers Calvin asked.

(1)

(d) Find the ratio of the number of teachers with 1 child to the number of teachers with 2 children. Give your ratio in its simplest form.

(2)

Q12. Amit has two fair spinners, spinner A and spinner B.

Spinner A has three sections, numbered 1, 2 and 4

Spinner B has four sections, numbered 1, 2, 3 and 5.

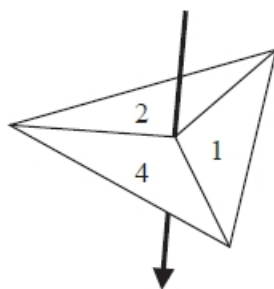

Spinner A

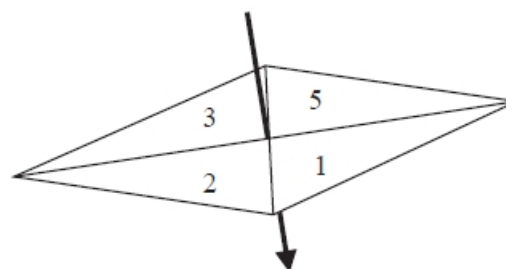

Spinner B

Amit spins each spinner once.

He adds together the number that spinner A lands on and the number that spinner B lands on to find the total.

(a) Complete the table to show all possible totals.

Four totals have been done for you.

	1	2	3	5
1	2	3		
2			5	
4				9

(2)

(b) Find the probability that the total is

(i) 5

(ii) an even number

(2)

Q13. Javier has two sets of cards.

Each set contains 4 cards, one marked A, one marked B, one marked C and one marked D.

Javier is going to take at random one card from each set.

The table shows all possible pairs of cards that Javier could take.

Set 2

		A	B	C	D
Set 1	A	AA	AB	AC	AD
	B	BA	BB	BC	BD
	C	CA	CB	CC	CD
	D	DA	DB	DC	DD

(a) Find the probability that Javier will take at least one card marked C.

(2)

Javier is going to take at random one card from each set, note the letter on each card and replace the cards.

He is going to do this a total of 80 times.

(b) Work out an estimate for the number of times that Javier will take at least one card marked C.

(2)

Q14. A box contains four different kinds of chocolates.

Debbie takes at random a chocolate from the box.

The table shows the probability of Debbie taking an Orange or a Coffee or a Caramel chocolate.

Chocolate	Probability
Orange	0.15
Coffee	0.40
Caramel	0.35
Strawberry	

(a) Work out the probability that Debbie takes a Strawberry chocolate.

(2)

(b) Work out the probability that Debbie takes an Orange chocolate or a Coffee chocolate.

Q15. Here is a fair 5-sided spinner.

Hans spins the spinner 30 times.

Work out an estimate for the number of times the spinner lands on Red.

(2)

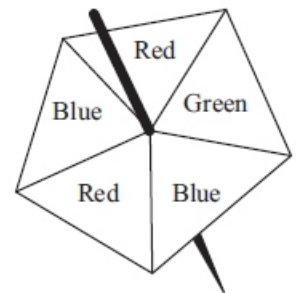

Q16. The pie chart shows information about the grades achieved by all of the candidates in Keval's school who took AS Level English in 2015.

(2)

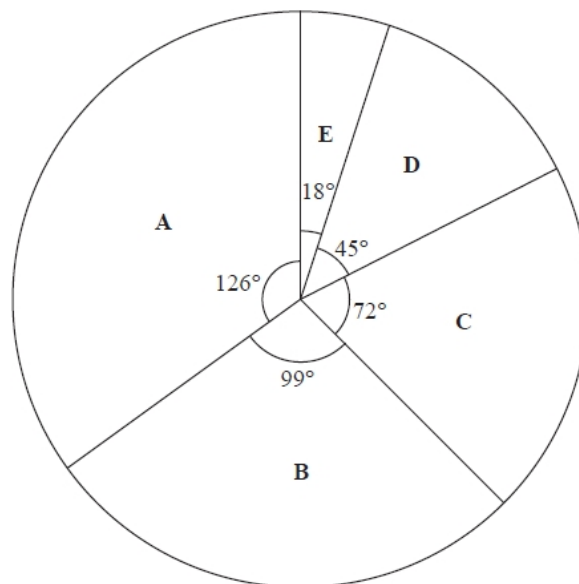

8 candidates achieved grade C.

(a) Work out the number of candidates in Keval's school who took AS Level English in 2015.

(2)

(b) Work out the number of candidates in Keval's school who achieved grade A in AS Level English in 2015.

(2)

Q17. Show that $\frac{3}{4} + \frac{4}{5} = 1\frac{11}{20}$

(2)

Q18.

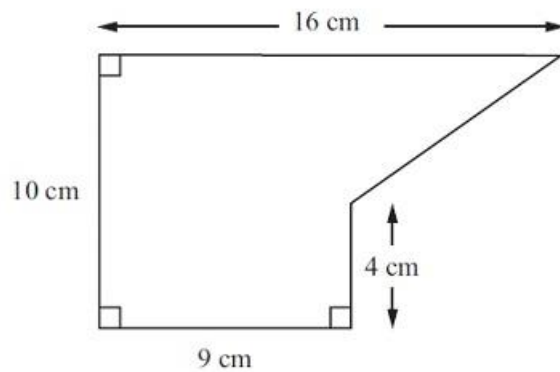

Diagram **NOT** accurately drawn

The diagram shows a shape.
Work out the area of the shape.

(2)

Q19. (a) Change 250 euros to yen.

1 euro = 120 yen
£1 = 1.2 euros

(2)

(b) Change 9000 yen to euros.

(2)

(c) Change £50 to yen.

.....yen

(2)

(Total for question = 6 marks)

Q20. The table shows the population, correct to two significant figures, of each of six countries in April 2016.

Country	Population (April 2016)
Hungary	9.8×10^6
Mexico	1.3×10^8
Thailand	6.8×10^7
Nigeria	1.9×10^8
Singapore	5.7×10^6
Egypt	9.3×10^7

(a) Write 9.3×10^7 as an ordinary number.

(1)

(b) Which of these countries had the least population?

(1)

The population of China was 1.382×10^9 in April 2016.

The population of India was 1.327×10^9 in April 2016.

(c) Work out the difference between the population of China and the population of India in April 2016. Give your answer in standard form.

(2)

Q21. (a) Find a fraction which is equivalent to $\frac{3}{5}$

(1)

b) Write $\frac{3}{5}$ as a decimal.

(1)

(c) Write $\frac{3}{5}$ as a percentage.

(1)

(d) Mathsville School has 875 students. $\frac{3}{5}$ of the students are girls.

(i) Work out $\frac{3}{5}$ of 875

(ii) Work out the fraction of the students who are boys.

8% of the students were born in May.

(iii) Work out 8% of 875

(5)

Q22. (a) Expand $6(4 - 3y)$

(1)

(b) Factorise $e^2 + 4e$

(1)

(c) Solve $7x + 8 = 2x - 3$
Show clear algebraic working.

(3)

(d) Expand and simplify $(y + 10)(y - 2)$

(2)

Q23. The diagram shows a circle with centre O and radius 6.5cm

(a) Work out the area of the circle.
Give your answer correct to 3 significant figures.

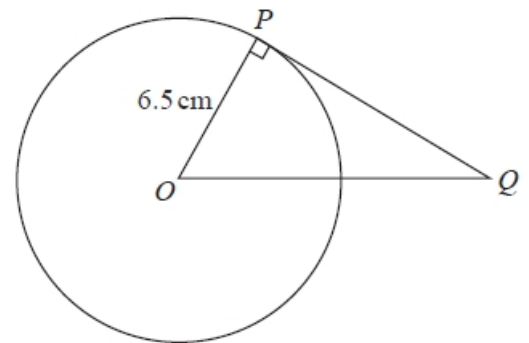

(2)

PQ is the tangent to the circle at P

$OQ = 10.5\text{cm}$

(b) Work out the length of PQ
Give your answer correct to 3 significant figures.

(3)

Q24. The diagram shows a cuboid.

The cuboid has length 10 cm , width 4 cm and height 7 cm .
Work out the volume of the cuboid.

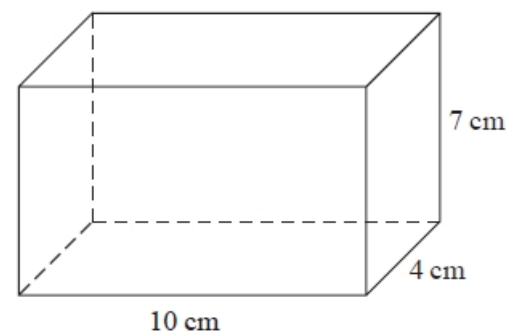

(2)

Q25. (a) There are 32 students in a class.
All the students are either left-handed or right-handed.
The ratio of the number of left-handed students to the number of right-handed students is 1 : 7

Work out the number of right-handed students.

(2)

(b) Sajid makes a scale model of a lorry.
He uses a scale of 1 : 32
The length of Sajid's model lorry is 45 cm.
Chitra makes a scale model of the same lorry.
She uses a scale of 1 : 72

Work out the length of Chitra's model lorry.

(3)

Q26. $\frac{5}{9}$ of the students in a group are male.

$\frac{5}{6}$ of the female students in the group are right-handed.

Work out the fraction of students in the group who are right-handed females.

(3)

Q27.

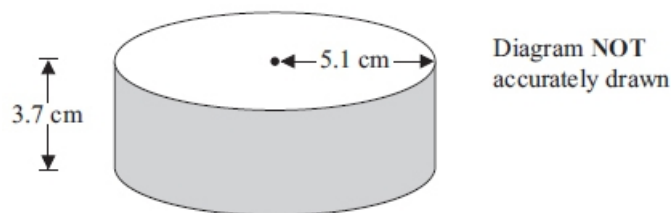

A solid cylinder has a radius of 5.1 cm and a height of 3.7 cm.
Work out the total surface area of the cylinder.
Give your answer correct to 3 significant figures.

(3)

Q28. (a) Write 8×10^4 as an ordinary number.

(1)

(b) Work out $(3.5 \times 10^5) \div (7 \times 10^8)$

Give your answer in standard form.

(2)

Q29. (a) Simplify

(i) $a \times 5 \times b \times c$

(ii) $q^5 + q^5 + q^5$

(iii) $7m + 6n - 2m - 9n$

(4)

(b) Factorise $t^2 - 10t$

(2)

Q30. (a) Simplify $8e + 2f - 11e + 3f$

(2)

(b) Expand $2y(3y - 7)$

(2)

Q31. (a) Factorise $3y^2 + 2y$

(1)

(b) Expand and simplify $(x - 9)(x + 2)$

(2)

(c) (i) Solve $6k + 5 < 20$

(ii) n is an integer and $6n + 5 < 20$

Write down the largest possible value of n .

(3)

Q32. (a) Complete the table of values for $y = x^2 + 2x - 3$

x	-4	-3	-2	-1	0	1	2
y		0	-3	-4			5

(2)

(b) On the grid, draw the graph of $y = x^2 + 2x - 3$ for values of x from -4 to 2

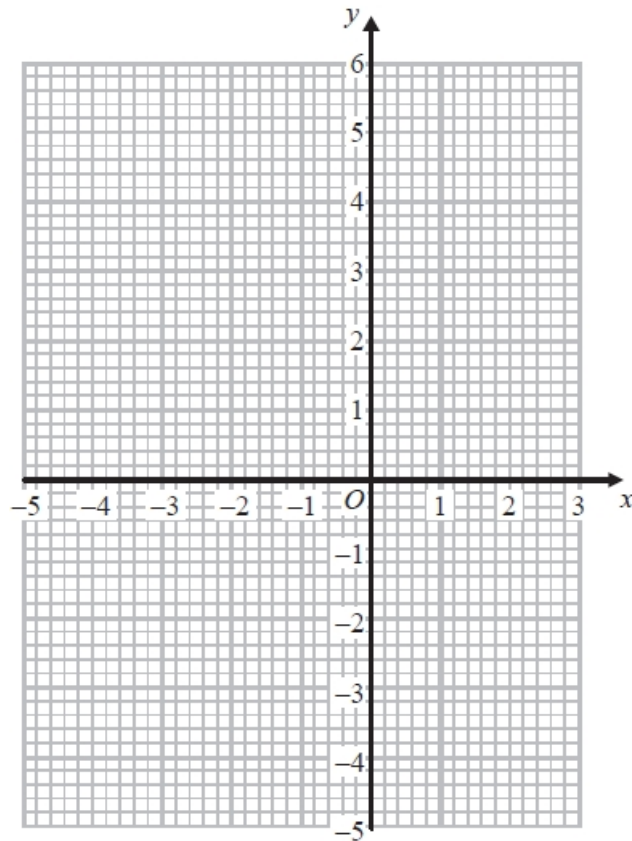

Q33. (a) Simplify $7 \times e \times 2 \times d$

(2)

(b) Simplify $m^5 \times m^2$

(1)

(c) Simplify $c^{11} \div c^3$

(1)

(d) Simplify $(a^5)^3$

(1)

(e) Expand and simplify $4(2x + 3) + 2(x + 5)$

(1)

(2)

Q34. The scale diagram shows the position of two ships, *A* and *B*.

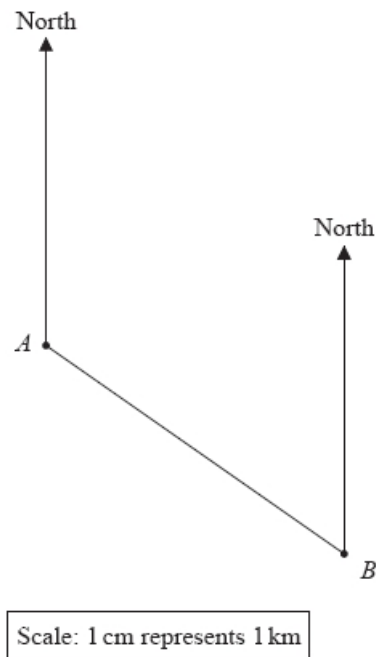

(a) Measure the bearing of *B* from *A*.

(1)

Another ship *C* is on a bearing of 070° from *B*.
Ship *C* is 7 km from *B*.

(b) Mark the position of ship *C* with a cross (×).

(2)

Q35. The diagram shows six triangles on a square grid.

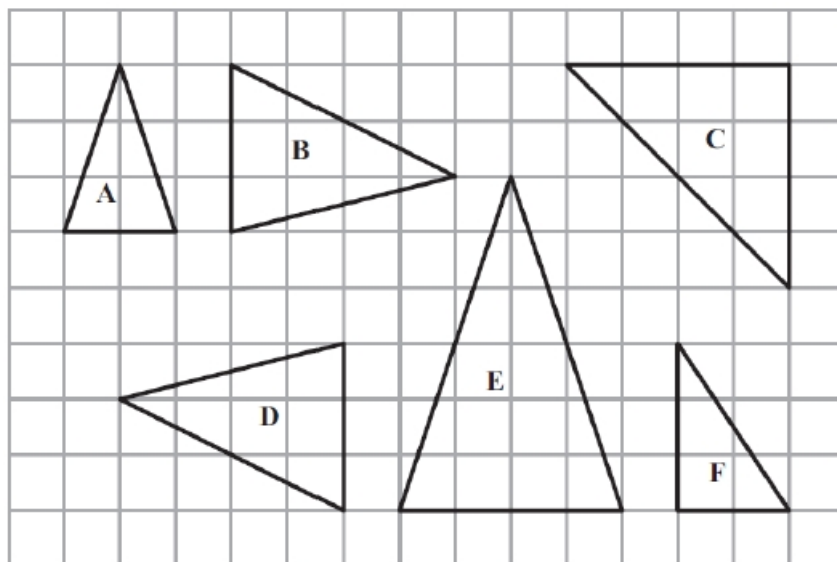

(a) Write down the mathematical name for triangle *A*.

(1)

(b) Write down the letters of the two triangles that are similar but not congruent.

(1)

- (c) Triangle D can be mapped onto triangle B by a rotation.
- On the grid, mark with a cross (×) the centre of this rotation.
 - Write down the angle of this rotation.

(2)

Q36. There are 6 batteries in a small packet of batteries.
There are 9 batteries in a large packet of batteries.

Chow buys m small packets of batteries and g large packets of batteries.

The total number of batteries Chow buys is T .

Write down a formula, in terms of m and g , for T .

(3)

Q37. A , B and C are points on a circle.

- (a) Write down the mathematical name for
- the line AB ,

- the shaded region.

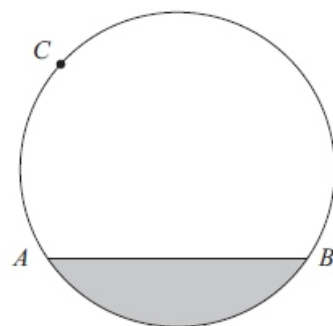

(2)

- (b) At the point C , draw a tangent to the circle.

(1)

Q38.

P and Q are points on a circle, centre C .

- (a) Write down the mathematical name for the line CP .

..... (1)

- (b) Measure the length of the line CP .

..... cm (1)

- (c) (i) Measure the size of angle C .

.....°

- (ii) Write down the mathematical name for this type of angle.

.....

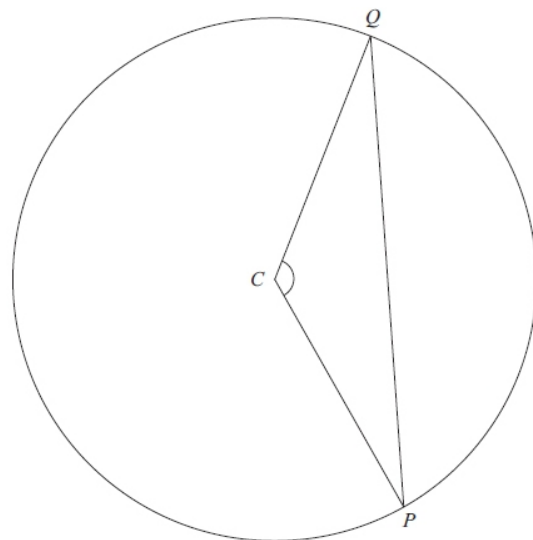

(2)

- (d) On the diagram, draw the line of symmetry of triangle CPQ .

(1)

- (e) Write down the mathematical name for triangle CPQ .

(1)

Q39. The diagram shows a right-angled triangle and a rectangle.

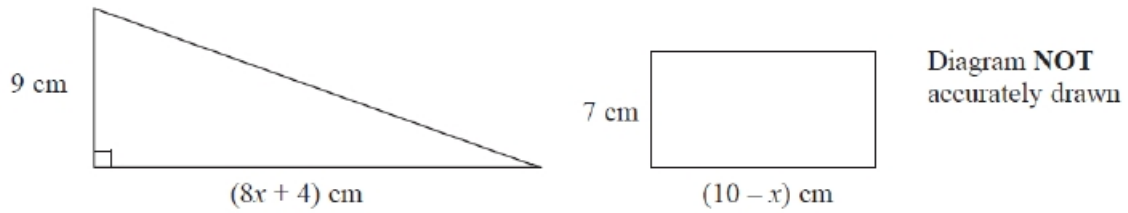

The area of the triangle is twice the area of the rectangle.

(i) Write down an equation for x .

(ii) Find the area of the rectangle. Show clear algebraic working.

(7)

Q40. Work out the value of x .
Give your answer correct to 1 decimal place.

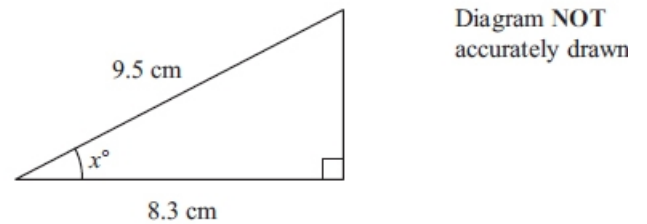

Q41. Work out the size of each exterior angle of a regular polygon with 15 sides.

(3)

(2)

Q42. The diagram shows a circle inside a rectangle.

Work out the area of the shaded region.
Give your answer correct to 3 significant figures.

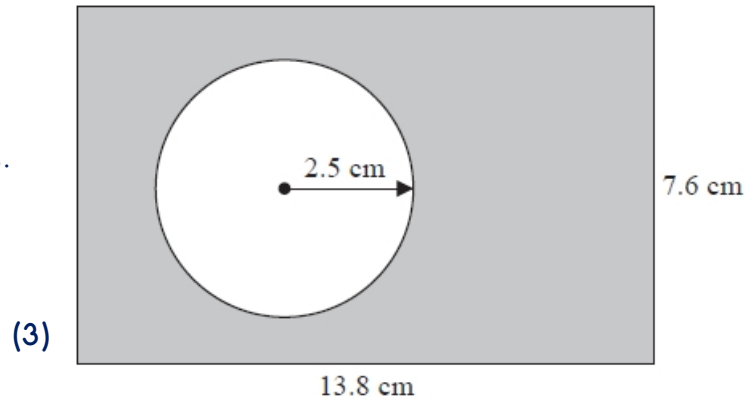

Q43. Work out the value of x .

Give your answer correct to 3 significant figures.

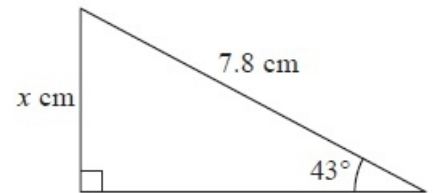

(3)

Q44. A circle has a diameter of 7.6 cm.

Work out the circumference of the circle.

Give your answer correct to 3 significant figures.

(2)

Q45. A total of 1200 passengers are booked to go on a cruise ship.

70% of the passengers will get on the ship at Southampton.

$\frac{1}{6}$ of the passengers will get on the ship at Lisbon.

The rest of the passengers will get on the ship at Venice.

(a) How many passengers will get on the ship at Venice?

(3)

There are 1200 passengers on the ship and 900 crew on the ship.

(b) Write down the ratio of the number of passengers to the number of crew.

Give your ratio in its simplest form.

